



Control Head for the integrated mounting on process valves

- Compact stainless steel design
- Integrated analog valve position registration (Teach function)
- Coloured illuminated status display
- Internal control air channel
- Fieldbus interface AS-Interface (option)

Type 8695 can be combined with...



Type 2101

Globe valve
actuator ø 50 mm



Type 2100

Angle-seat valve
actuator ø 50 mm



Type 2103

Diaphragm valve
actuator ø 50 mm

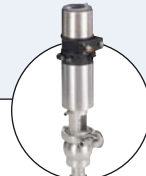

**Customised
adaption**

The control head Type 8695 is optimised for integrated mounting on the 21XX process valve series with smaller actuator sizes.

The registration of the valve position is done through a contact-free analog position sensor, which automatically recognises and saves the valve end position through the Teach function when starting up. The integrated pilot valve controls single or double-acting actuators.

The design of the control unit and the actuator is specially designed for the requirements of a hygienic process environment and enables an internal control air channel without external tubings.

Besides the electrical position feedback signal the status of the device is shown directly on the control head itself through coloured LEDs showing a clear visible valve position status.

As an option a fieldbus interface, AS-Interface, can be chosen.

Technical data

Material	Body Cover Sealing	PPS, stainless steel PC EPDM
Control medium	Dust concentration Particle density Pressure condensation point Oil concentration	neutral gases, air DIN ISO 8573-1 Class 5 (<40µm particle size) Class 5 (<10mg/m ³) Class 3 (<-20°C) Class 5 (<25mg/m ³)
Supply pressure		0 to 7 bar ¹⁾
Actuator system	Actuator series 21XX	for single or double-acting actuators actuator ø 50 mm
Pilot air ports		Push-in connector (external ø 6 mm or 1/4") or threaded ports G1/8
Position feedback		Analog position sensor (contact-free) with autotune switchpoint (PNP) (NPN on request)
Stroke range valve spindle		2 to 28 mm (2 to 45 mm on request)
Ambient temperature		0 to +55 °C
Installation		as required, preferably with actuator in upright position
Protection class		IP 65/67 according to EN 60529 (NEMA4x in preparation)
Protection class		3 according to VDE 0580
Fieldbus communication		AS-Interface (option)
Conformity		according to CE in compliance with EMV2004/108/EG
Type of protection		II 3 G nA II B T4 II 3 D tD A22 T135°
Electrical connection	Multipole	M12, 8-pins or M12 4-pins (AS-Interface)
Approval		CSA (in preparation)

1) The supply pressure has to be 0,5 - 1 bar above the minimum required pilot pressure for the valve actuator.

Technical data, continued

Without fieldbus communication

Technical data	
Power supply	24 VDC
Residual ripple with DC	10% no technical direct current!
Voltage tolerance	±10%
Power consumption	< 2W
Electrical connection	Multipole
Output	M12, 8-pole max. 100 mA per output

With fieldbus communication; AS-Interface

Technical data	
Profile	S-B.A.E. (A/B slave, max. 62 slaves/master)
Power supply through bus line separated from bus signal	29.5 to 31.6 VDC according to specification on request
Power consumption Units without external power supply Max. power consumption Power consumption in normal operation (after current reduction; Valve + 1 end position achieved)	120 mA 90 mA
Output Contact rating Watch-dog function	≤ 1W over AS-Interface integrated
Electrical connection	M12 4-pins
Programming data	see operating instructions

Ordering information for process valve system with integrated control head

A complete process valve system consists of a Control Head Type 8695 and a process valve Type 21xx.

The following information is necessary for the selection of a complete system:

• **Item no.** of the desired control head **Type 8695** (see ordering chart on p. 4)

• **Item no.** of the desired process valve **Type 21xx**
(see separate datasheet e.g. Type 2100, 2101, 2103)

You order two components and receive a complete assembled and certified valve.

When you click on the orange box "More info." below, you will come to our website for the resp. product where you can download the datasheet.

Example for process valve systems

Control Head Type 8695



Desired process valve, example

More info.



2101
Globe valve
actuator
ø 50 mm

More info.



2100
Angle-seat
valve
actuator
ø 50 mm

More info.



2103
Diaphragm
valve
actuator
ø 50 mm

Complete process valve system



Valve system
On/Off ELEMENT
Type 8801-GC-M
2101 + 8695



Valve system
On/Off ELEMENT
Type 8801-YE-M
2100 + 8695



Valve system
On/Off ELEMENT
Type 8801-DF-M
2103 + 8695

Ordering chart Control Head Type 8695 (other versions on request)

Communication	Electrical connection	Valve function	Position feedback	Pilot air ports	Item no.
Actuator size Ø 50 mm					
AS-Interface	Multipole	single-acting	2 switching points	Push-in connector external ø 6 mm or 1/4"	185 116
				Threaded ports G1/8	185 117
		double-acting	2 switching points	Push-in connector external ø 6 mm or 1/4"	204 141
				Threaded ports G1/8	204 142
No	Multipole	single-acting	2 switching points	Push-in connector external ø 6 mm or 1/4"	185 114
				Threaded ports G1/8	185 115
		double-acting	2 switching points	Push-in connector external ø 6 mm or 1/4"	201 139
				Threaded ports G1/8	201 140

Further versions on request



Approvals
CSA



Additional
Switchpoint NPN-coded

Ordering chart adapter kit (has to be ordered separately)

Description	Actuator size	Control function	Item no.
Adapter kit for Type 21xx	ø 50 mm	NC / NO (A / B)	673 765

Ordering chart accessories

Description	Item no.
M12 socket, 8-pins, 2 m assembled cable	919 061
M12 socket, 4-pins, 5 m assembled cable	918 038
Silencer G1/8	780 779
Silencer, push-in connector	902 662

Materials

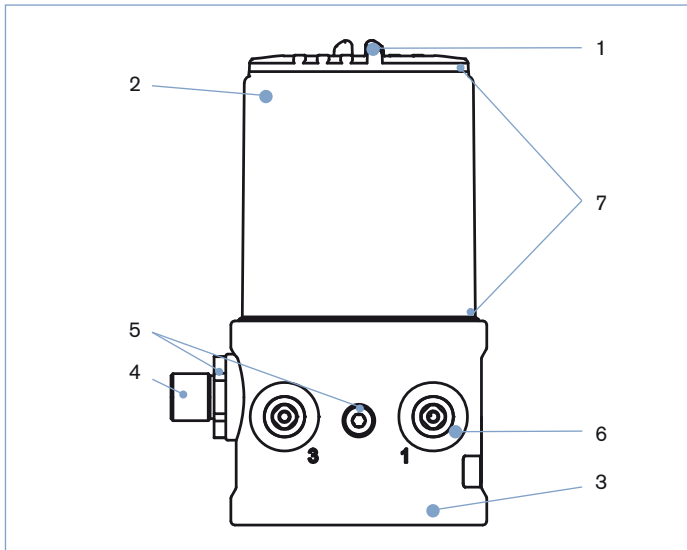

1 Cover	PC
2 Body casing	Stainless steel
3 Basic body	PPS
4 Plug M12	Stainless steel
5 Screws	Stainless steel
6 Push-in connector	POM/stainless steel
Threaded ports G1/8	Stainless steel
7 Sealing	EPDM

Dimensions [mm]

Mounting on process valve Type 21xx

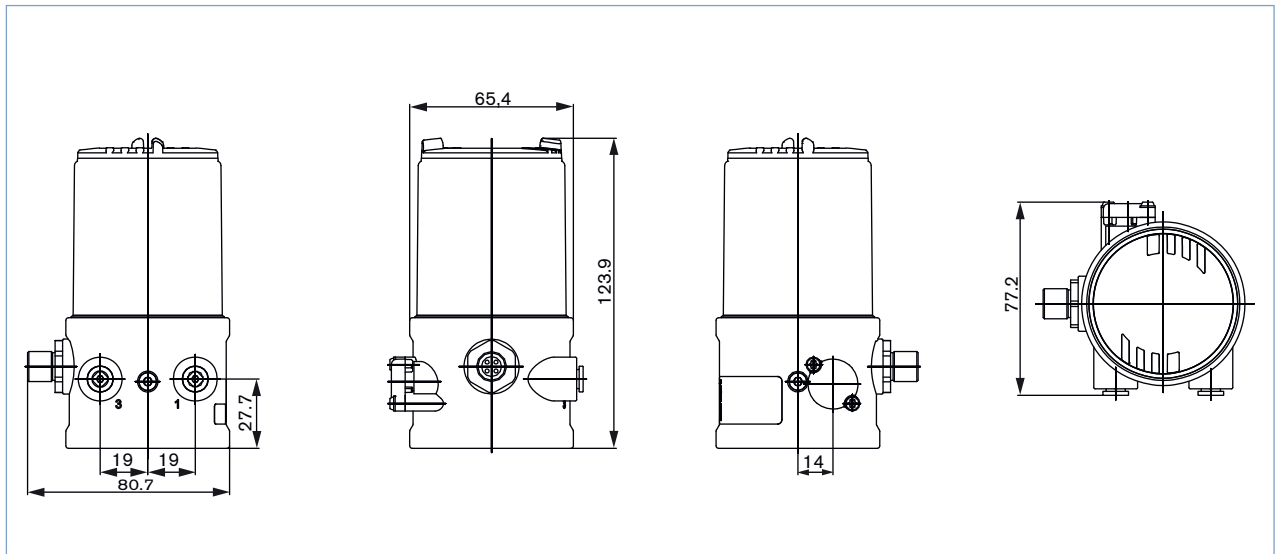

Electrical installation

AS-Interface

Multipole connection AS-Interface

Bus connection (M12-circular connector, 4-pins, male)

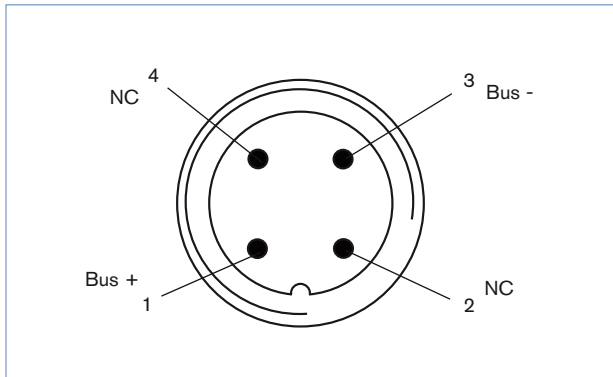

Pin	Description	Configuration
1	Bus +	bus line AS-Interface +
2	NC	not assigned
3	Bus -	bus line AS-Interface -
4	NC	not assigned

24 V DC

Multipole connection M12, 8-pins

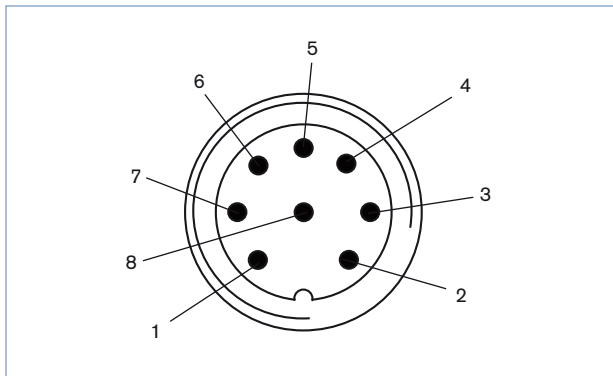

Pin	Description	Configuration
1	Limit switch 1	IN 1
2	Limit switch 2	IN 2
3	Power supply	GND
4	Operating voltage +	24 V DC
5	Valve control +	Valve +
6	Valve control -	Valve
7	n.a.	not assigned
8	n.a.	not assigned

To find your nearest Bürkert facility, click on the orange box →

www.burkert.com

In case of special application conditions,
please consult for advice.

Subject to alteration.
© Christian Bürkert GmbH & Co. KG

0909/3_EU-en_00895094