

Full Bore Magflowmeter - General purpose version

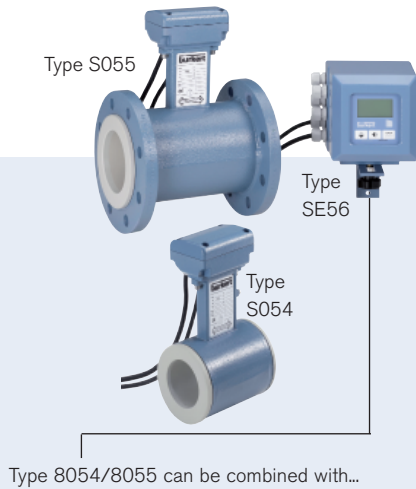

- Combination of magflowsensor fitting S054 or S055 and electronics SE56
- Continuous measurement or Batch Control
- Version without (S054) or with (S055) flanges
- For water treatment and general purpose applications

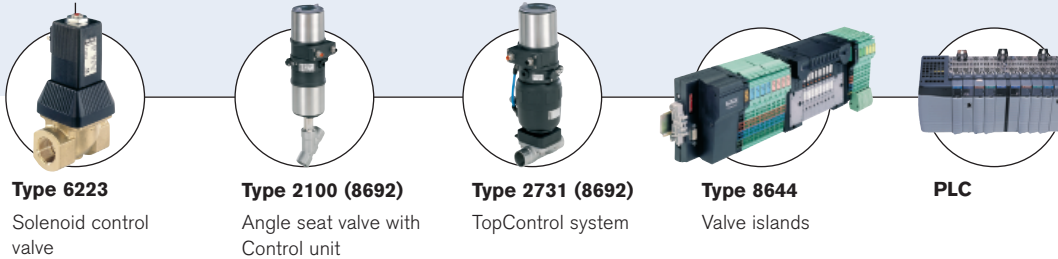

The complete full bore magflowmeter Type 8054/8055, which consists of a magnetic sensor fitting Type S054 or S055 connected to an electronics Type SE56 (blind in compact version or with display in compact or remote version), is designed for applications with liquids with a minimum conductivity of 5 µS/cm.

Combined with a valve as the actuating element, the complete full bore magflowmeter Type 8054/8055 can control high-precision dosing operations and flow measurements in potable water treatment and waste water treatment.

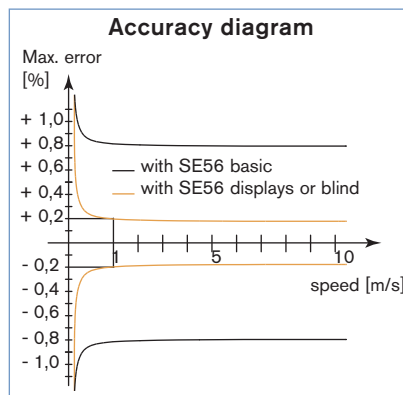

General data - S054/S055 sensor fitting	
Compatibility	SE56 electronics (see corresponding data sheet)
Materials	
Body	Carbon steel painted [or stainless steel 304 or 316]*
Electrodes (3 in standard)	Stainless steel 316L [or Hastelloy C, Titanium, Tantalum, Platinum-rhodium]*
Lining	PP (max. 16 bar), ebonite [or PTFE]*
Seal	FKM or EPDM* (with PP lining) [or without gasket (with PTFE lining)]
Electrical connection	2 cable glands (PG9)

Complete magflowmeter 8054/8055 data - (S054/S055 sensor fitting+ SE56 electronics)	
Pipe diameter	DN25 up to DN200 [up to DN2000]*
Measuring range	0 m³/h ... 0.72 m³/h up to 0 m³/h ... 1130 m³/h
Process connection	S054: wafer - S055: Flange EN1092-1, ANSI B16-5, [JIS]*
Medium temperature	see medium temperature chart on page 3 go to page
Medium pressure max.	PN16 (232 PSI) (with PP lining) or [up to PN64 (928 PSI) (with Ebonite or PTFE lining)]*
Vacuum resistance	200 mbar (2.9 PSI) absolute at 100°C (212°F)
Accuracy ¹⁾ see diagram, opposite	± 0.2% of reading (SE56 standard; SE56 blind) ± 0.8% of reading (SE56 basic)
Repeatability	± 0.1% (SE56 standard; SE56 blind) ± 0.2% (SE56 basic)
Minimum conductivity	5 µS/cm (or 20 µS/cm with demineralized water)

* on request

¹⁾ under reference conditions: water temperature = 20°C, ambient temperature = 25°C, constant flow rate during the test, liquid speed > 1 m/s

Environment	
Ambient temperature with	
SE56 standard	-20°C up to 60°C (-4°F up to 140°F) (operating and storage)
SE56 basic	-10°C up to 50°C (14°F up to 122°F) (operating)
	-20°C up to 50°C (-4°F up to 122°F) (storage)
SE56 blind	-20°C up to 40°C (-4°F up to 104°F) (operating and storage)
Standard	
Protection class	IP65 and IP67 (compact version, SE56 standard or SE56 blind); IP65 (remote version, SE56 standard) IP68 (remote version and junction box filled with resin, SE56 standard); IP65 (compact version, SE56 basic)
Standard	
EMC	EN 61326-1,
Emission / Immunity	EN 55011 (Group 1, Class B) / IEC 1000-4-2/3/4/5/6/11
Safety	EN 61010

Ordering information for complete full bore magflowmeter Type 8054/8055

A complete full bore magflowmeter Type 8054 respectively 8055 consists of a sensor fitting S054 or S055 and an electronics SE56. The electronics is only delivered in combination with the sensor fitting as a part of a complete magflowmeter.

The following information is necessary for the selection of a complete full bore magflowmeter:

- **item no.** of the sensor fitting **Type S054 or S055** (see Ordering Chart)
- **item no.** of the electronics **Type SE56** (see corresponding data sheet or Ordering chart on page 7)

More info.

For more technical information about this product, click on this box... you will come to our website for this product where you can download the datasheet.

Examples for variations of complete full bore magflowmeter

Electronics Type SE56

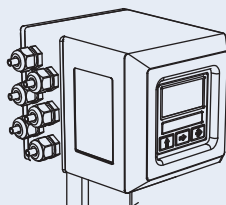

Standard with display
compact version

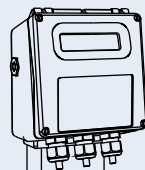

Basic (with or without display)
compact version

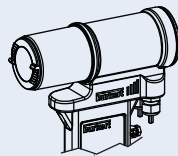

Without display (blind)
compact version

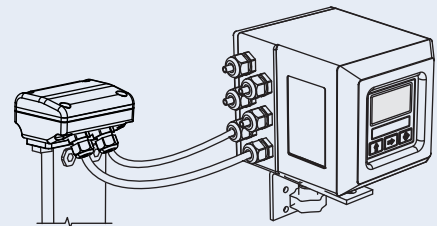

Standard with display
Remote version

Sensor fitting Type S054 or Type S055

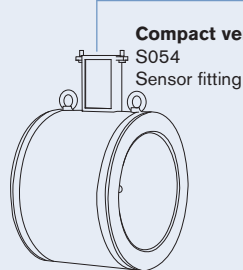

Compact version
S054
Sensor fitting

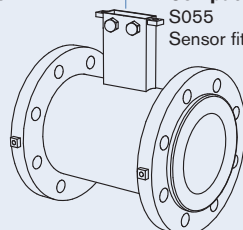

Compact version
S055
Sensor fitting

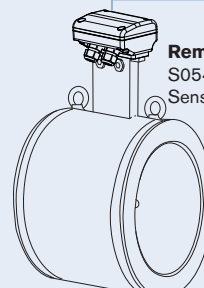

Remote version
S054
Sensor fitting

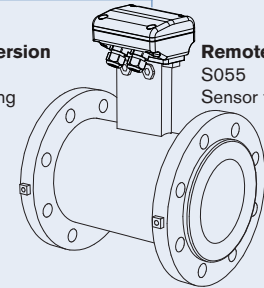

Remote version
S055
Sensor fitting

Design and operating principle

The sensor fitting Type S054 or S055 consists of a stainless steel pipe section internally lined with insulating material. Two electrodes mounted opposite to each other on the internal surface of the tube generate an electrical signal. The coils generating the magnetic field are placed outside the pipe. The signal generated by the sensor fitting S054 or S055 must be amplified and processed by an electronics (SE56) which outputs an electrical signal proportional to the fluid flow velocity.

Faraday's induction law is the basis for this magnetic flow measurement.

Installation



Avoid the functioning with the pipe partially filled.

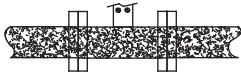

During flowmeter operation the pipe must be completely full.

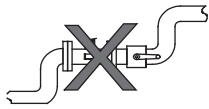

Avoid the installation near curves or hydraulic accessories.

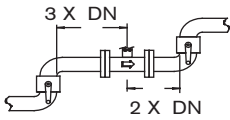

Observe the upstream and downstream distances.

The sensor fitting can be installed into either horizontal or vertical pipes. Mount the S054 or S055 sensor fitting the below as correct indicated ways to obtain an accurate flow measurement.

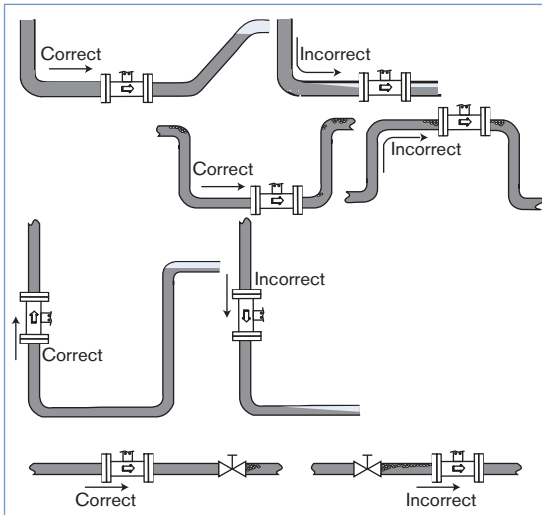

The suitable pipe size is selected using the diagram Flow / Velocity / DN

(see diagram to the right). The flow sensor fitting is not designed for gas flow measurement.

Diagram Flow / Velocity / DN

Example:





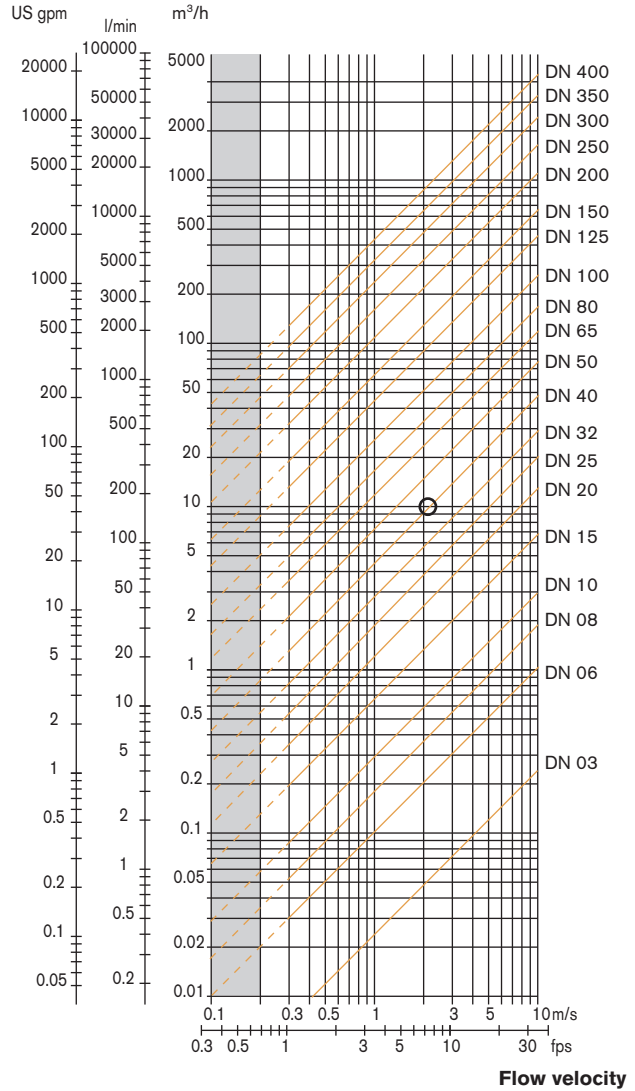

- Specification of nominal flow: 10 m³/h
- Ideal flow velocity: 2...3 m/s
- For these specifications, the diagram indicates a pipe size of DN40

Flow rate



DTS 1000101296 EN Version: H Status: RL (released | freigegeben | validé) printed: 27.06.2011

Medium temperature chart

	SE56 standard compact 	SE56 standard remote 	SE56 basic compact 	SE56 blind compact 
	0°C up to 60°C (32°F up to 140°F)	0°C up to 60°C (32°F up to 140°F)	0°C up to 60°C (32°F up to 140°F)	0°C up to 60°C (32°F up to 140°F)
	-20°C up to 100°C (-4°F up to 212°F)	-20°C up to 130°C (-4°F up to 266°F)	-10°C up to 100°C (14°F up to 212°F)	-20°C up to 100°C (-4°F up to 212°F)

Dimensions [mm] of Type S054 sensor fitting - wafer version

NOTE: Dimensions of SE56 electronics, see corresponding data sheet.

Compact version

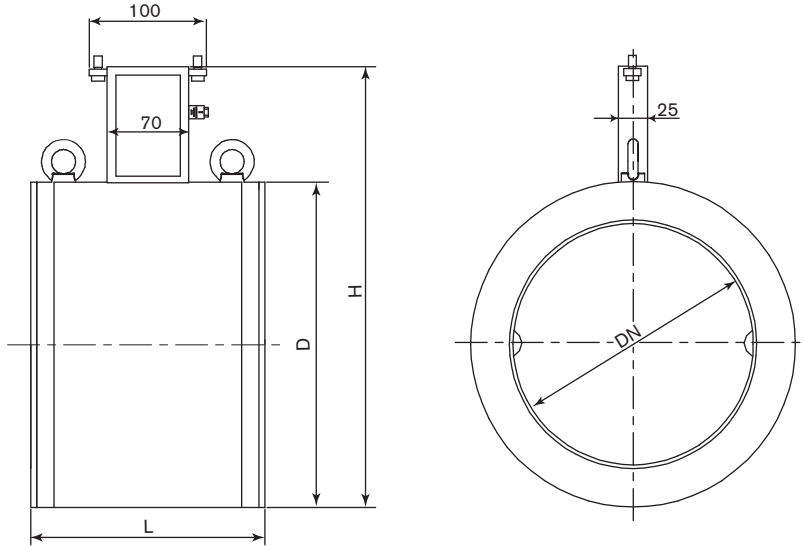

Remote version, with junction box

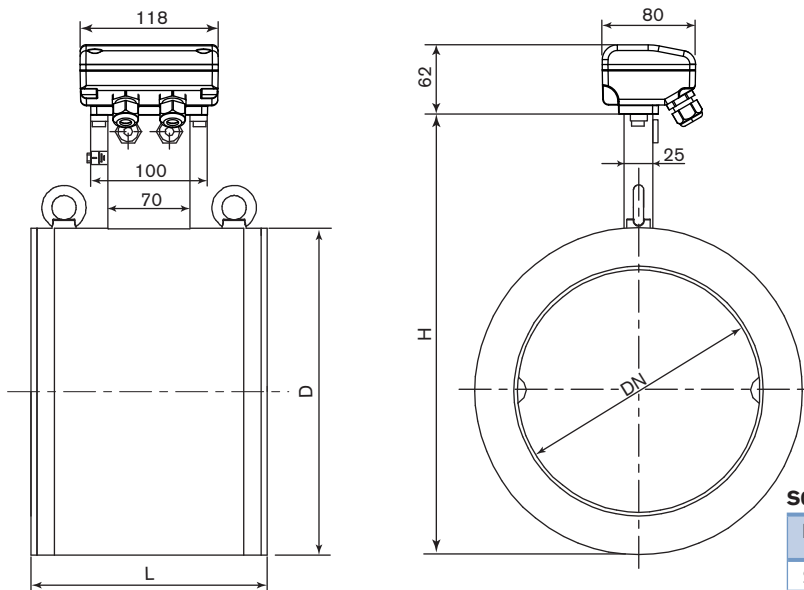

S054 compact or remote

DN	L*	H	D
25	100	147	56
32	100	153	62
40	100	161	70
50	100	177	86
65	150	199	108
80	150	209	118
100	150	235	144
125	180	263	172
150	180	291	200
200	200	362	271

* tolerance +0 mm
-3 mm

Dimensions [mm] of Type S055 sensor fitting - flanged version

NOTE: Dimensions of SE56 electronics, see corresponding data sheet.

Compact version

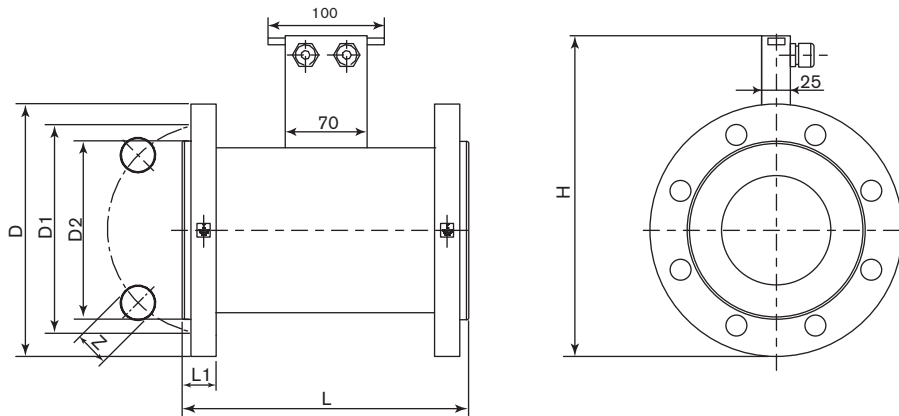

Remote version, with junction box

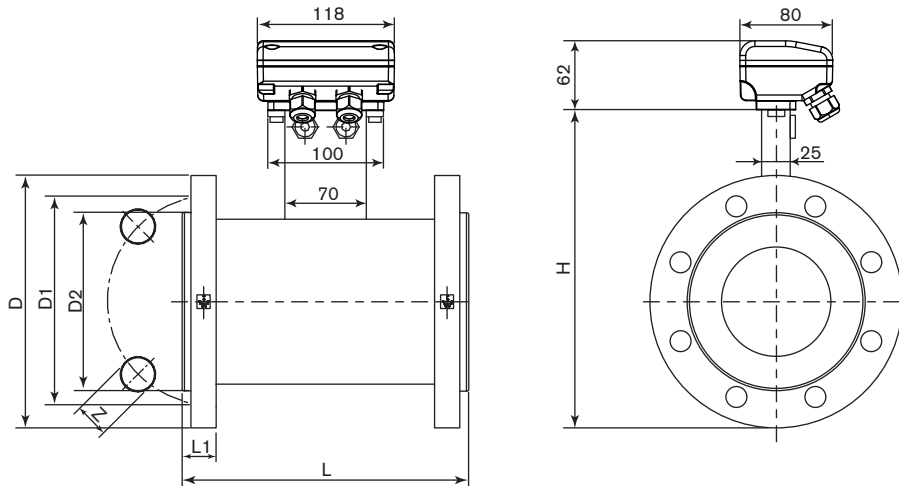

S055 compact or remote, with flanges PN16

DN	H	L	Standard	L1	Z	D2	D1	D
25	185	200	EN1092-1	18	4 x 14	68	85	115
	182		ANSI 150 RF	16.3	4 x 15.9	50.8	79.4	107.9
32	203	200	EN1092-1	18	4 x 18	78	100	140
	192		ANSI 150 RF	17.9	4 x 15.9	63.5	88.9	117.5
40	213	200	EN1092-1	18	4 x 18	88	110	150
	202		ANSI 150 RF	19.5	4 x 15.9	73	98.4	127
50	228	200	EN1092-1	18	4 x 18	102	125	165
	222		ANSI 150 RF	21.1	4 x 19	92.1	120.7	152.4
65	248	200	EN1092-1	18	4 x 18	122	145	185
	245		ANSI 150 RF	24.3	4 x 19	104.8	139.7	177.8
80	263	200	EN1092-1	20	8 x 18	138	160	200
	258		ANSI 150 RF	25.9	4 x 19	127	152.4	190.5
100	283	250	EN1092-1	20	8 x 18	158	180	220
	287		ANSI 150 RF	25.9	8 x 19	157.2	190.5	228.6
125	313	250	EN1092-1	22	8 x 18	188	210	250
	315		ANSI 150 RF	25.9	8 x 22.2	185.7	215.9	254
150	344	300	EN1092-1	22	8 x 22	212	240	285
	341		ANSI 150 RF	27.4	8 x 22.2	215.9	241.3	279.4
200	399	350	EN1092-1	24	12 x 22	268	295	340
	401		ANSI 150 RF	30.6	8 x 22.2	269.9	298.5	342.9

Ordering chart for universal magflowmeter 8054/8055

A complete magflowmeter Type 8054/8055 consists of:

- a full bore sensor fitting, wafer version Type S054 or flanges version Type S055
- an electronics Type SE56

Please order the relevant sensor fitting and the electronics remotely!

Full bore Sensor fitting Type S054 or S055

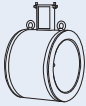
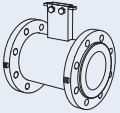
Description	DN [mm]	Process connection	Flow rate range [m ³ /h]		Body material	Number of electrodes	Electrode material	Lining material	Item no.
			min. 0..0.4 m/s	max. 0..10 m/s					
Type S054 Compact version 	25	Wafer type	0 ... 0.72	0 ... 18	Carbon steel	3 (2 measure + 1 for ground)	SS 316L	PP	554 532
	32	Wafer type	0 ... 1.16	0 ... 29	Carbon steel	3 (2 measure + 1 for ground)	SS 316L	PP	559 435
	40	Wafer type	0 ... 1.80	0 ... 45	Carbon steel	3 (2 measure + 1 for ground)	SS 316L	PP	554 101
	50	Wafer type	0 ... 2.88	0 ... 72	Carbon steel	3 (2 measure + 1 for ground)	SS 316L	PP	554 700
	65	Wafer type	0 ... 4.80	0 ... 120	Carbon steel	3 (2 measure + 1 for ground)	SS 316L	PP	559 436
	80	Wafer type	0 ... 7.20	0 ... 180	Carbon steel	3 (2 measure + 1 for ground)	SS 316L	PP	554 142
	100	Wafer type	0 ... 11.20	0 ... 280	Carbon steel	3 (2 measure + 1 for ground)	SS 316L	PP	554 342
	125	Wafer type	0 ... 18.00	0 ... 450	Carbon steel	3 (2 measure + 1 for ground)	SS 316L	PP	562 953
	150	Wafer type	0 ... 25.60	0 ... 640	Carbon steel	3 (2 measure + 1 for ground)	SS 316L	PP	562 954
	200	Wafer type	0 ... 45.20	0 ... 1130	Carbon steel	3 (2 measure + 1 for ground)	SS 316L	Ebonite	561 912
Type S055 Compact version 	25	EN1092-1	0 ... 0.72	0 ... 18	Carbon steel	2 (2 measure)	SS 316L	PP	553 540
		ANSI 150 RF	0 ... 0.72	0 ... 18	Carbon steel	2 (2 measure)	SS 316L	PP	554 353
	32	EN1092-1	0 ... 1.16	0 ... 29	Carbon steel	2 (2 measure)	SS 316L	PP	553 541
		ANSI 150 RF	0 ... 1.16	0 ... 29	Carbon steel	2 (2 measure)	SS 316L	PP	560 047
	40	EN1092-1	0 ... 1.80	0 ... 45	Carbon steel	2 (2 measure)	SS 316L	PP	553 542
		ANSI 150 RF	0 ... 1.80	0 ... 45	Carbon steel	2 (2 measure)	SS 316L	PP	560 048
	50	EN1092-1	0 ... 2.88	0 ... 72	Carbon steel	2 (2 measure)	SS 316L	PP	553 485
		ANSI 150 RF	0 ... 2.88	0 ... 72	Carbon steel	2 (2 measure)	SS 316L	PP	554 354
	65	EN1092-1	0 ... 4.80	0 ... 120	Carbon steel	2 (2 measure)	SS 316L	PP	553 393
		ANSI 150 RF	0 ... 4.80	0 ... 120	Carbon steel	2 (2 measure)	SS 316L	PP	558 785
	80	EN1092-1	0 ... 7.20	0 ... 180	Carbon steel	2 (2 measure)	SS 316L	PP	553 394
		ANSI 150 RF	0 ... 7.20	0 ... 180	Carbon steel	2 (2 measure)	SS 316L	PP	554 351
	100	EN1092-1	0 ... 11.20	0 ... 280	Carbon steel	2 (2 measure)	SS 316L	PP	553 489
		ANSI 150 RF	0 ... 11.20	0 ... 280	Carbon steel	2 (2 measure)	SS 316L	PP	554 352
	125	EN1092-1	0 ... 18.00	0 ... 450	Carbon steel	2 (2 measure)	SS 316L	PP	559 318
		ANSI 150 RF	0 ... 18.00	0 ... 450	Carbon steel	2 (2 measure)	SS 316L	PP	562 955
	150	EN1092-1	0 ... 25.60	0 ... 640	Carbon steel	2 (2 measure)	SS 316L	PP	557 512
		ANSI 150 RF	0 ... 25.60	0 ... 640	Carbon steel	2 (2 measure)	SS 316L	PP	561 426
200	EN1092-1	0 ... 45.20	0 ... 1130	Carbon steel	2 (2 measure)	SS 316L	Ebonite	554 217	
	ANSI 150 RF	0 ... 45.20	0 ... 1130	Carbon steel	2 (2 measure)	SS 316L	Ebonite	560 568	

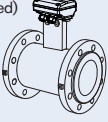
Description	DN [mm]	Process connection	Flow rate range [m ³ /h]		Body material	Number of electrodes	Electrode material	Lining material	Item no.
			min. 0...0.4 m/s	max. 0...10 m/s					
Type S055 Remote version with 10 m cable (included) 	25	EN1092-1	0 ... 0.72	0 ... 18	Carbon steel	2 (2 measure)	SS 316L	PP	448 492
		ANSI 150 RF	0 ... 0.72	0 ... 18	Carbon steel	2 (2 measure)	SS 316L	PP	559 598
	32	EN1092-1	0 ... 1.16	0 ... 29	Carbon steel	2 (2 measure)	SS 316L	PP	448 493
		ANSI 150 RF	0 ... 1.16	0 ... 29	Carbon steel	2 (2 measure)	SS 316L	PP	562 958
	40	EN1092-1	0 ... 1.80	0 ... 45	Carbon steel	2 (2 measure)	SS 316L	PP	448 494
		ANSI 150 RF	0 ... 1.80	0 ... 45	Carbon steel	2 (2 measure)	SS 316L	PP	559 599
	50	EN1092-1	0 ... 2.88	0 ... 72	Carbon steel	2 (2 measure)	SS 316L	PP	448 495
		ANSI 150 RF	0 ... 2.88	0 ... 72	Carbon steel	2 (2 measure)	SS 316L	PP	562 128
	65	EN1092-1	0 ... 4.80	0 ... 120	Carbon steel	2 (2 measure)	SS 316L	PP	448 496
		ANSI 150 RF	0 ... 4.80	0 ... 120	Carbon steel	2 (2 measure)	SS 316L	PP	562 959
	80	EN1092-1	0 ... 7.20	0 ... 180	Carbon steel	2 (2 measure)	SS 316L	PP	448 497
		ANSI 150 RF	0 ... 7.20	0 ... 180	Carbon steel	2 (2 measure)	SS 316L	PP	562 129
	100	EN1092-1	0 ... 11.20	0 ... 280	Carbon steel	2 (2 measure)	SS 316L	PP	448 498
		ANSI 150 RF	0 ... 11.20	0 ... 280	Carbon steel	2 (2 measure)	SS 316L	PP	555 666
	125	EN1092-1	0 ... 18.00	0 ... 450	Carbon steel	2 (2 measure)	SS 316L	PP	560 144
		ANSI 150 RF	0 ... 18.00	0 ... 450	Carbon steel	2 (2 measure)	SS 316L	PP	562 956
	150	EN1092-1	0 ... 25.60	0 ... 640	Carbon steel	2 (2 measure)	SS 316L	PP	554 141
		ANSI 150 RF	0 ... 25.60	0 ... 640	Carbon steel	2 (2 measure)	SS 316L	PP	561 952
	200	EN1092-1	0 ... 45.20	0 ... 1130	Carbon steel	2 (2 measure)	SS 316L	Ebonite	559 753
		ANSI 150 RF	0 ... 45.20	0 ... 1130	Carbon steel	2 (2 measure)	SS 316L	Ebonite	562 135

i Further versions on request

Remote sensor fitting version Type S054. Please also use the "request for quotation" form on page 9 for ordering a customized sensor fitting [go to page](#).

Electronics Type SE56 (for more data, refer to data sheet Type SE56)

Description	Power supply	Outputs	Body material	Electrical connection	Item no.
Standard compact version with local display	90...265 V AC	2 transistors	Aluminium	6 cable glands	558 745
			Stainless steel	6 cable glands	559 780
		2 transistors + 4...20 mA	Aluminium	6 cable glands	558 747
			Stainless steel	6 cable glands	558 306
Standard wall-mounting version with local display	90...265 V AC	2 transistors	Aluminium	6 cable glands	559 781
			Stainless steel	6 cable glands	558 310
		2 transistors + 4...20 mA	Aluminium	6 cable glands	558 750
			Stainless steel	6 cable glands	558 308
Basic compact version with display	90...265 V AC	2 transistors	Nylon	3 cable glands	562 439
		2 transistors + 4...20 mA	Nylon	3 cable glands	562 440
	18...63 V DC	2 transistors	Nylon	3 cable glands	562 443
		2 transistors + 4...20 mA	Nylon	3 cable glands	562 444
Basic compact version without display	90...265 V AC	2 transistors	Nylon	3 cable glands	562 441
		2 transistors + 4...20 mA	Nylon	3 cable glands	562 442
	18...63 V DC	2 transistors	Nylon	3 cable glands	562 445
		2 transistors + 4...20 mA	Nylon	3 cable glands	562 446
Blind compact version	20...30 V DC	up to 4 transistors	Stainless steel	2 cable glands	559 132
		up to 4 transistors + 4...20 mA	Stainless steel	2 cable glands	559 133
		up to 4 transistors + PROFIBUS DP	Stainless steel	2 cable glands	559 134

Ordering chart for spare parts/accessories for sensor fitting Type S054 or S055

Description	Purpose	No. on drawing	Item no.
Electrode cable, 10 m long	for connection between sensor fitting Type S054/S055 without junction box, S051 or S056 and electronics Type SE56*	1	448 518
	for connection between sensor fitting Type S054/S055 with junction box and electronics Type SE56* or for connection between extension cable kit and electronics Type SE56*	4	562 851
Coil cable, 10 m long	for connection between sensor fitting Type S054/S055 without junction box S051 or S056 and electronics Type SE56*	2	448 519
	for connection between sensor fitting Type S054/S055 with junction box and electronics Type SE56* or for connection between extension cable kit and electronics Type SE56*	5	562 852
Extension cable kit	including a connecting box and resin	3	562 853

* (see corresponding data sheet)

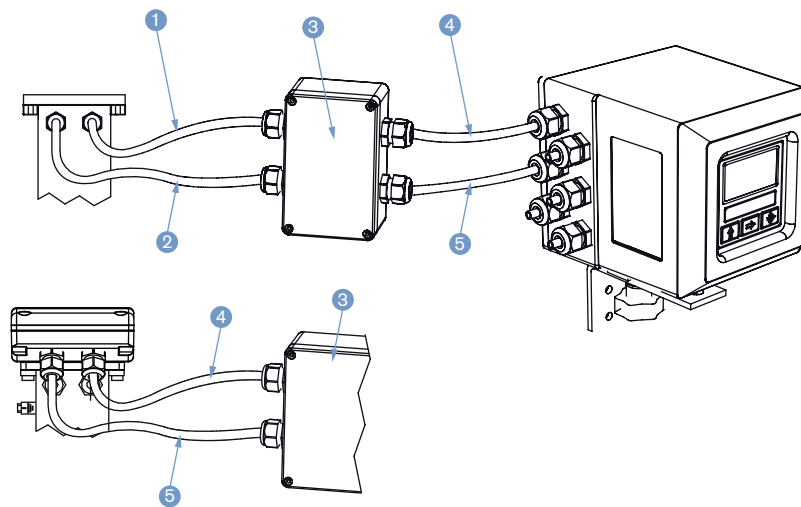
i Further versions on request

Electrical connection

Electrode and coil cables length

Universal sensor fitting Type S054 or S055 - request for quotation

Note
You can fill out the fields directly in the PDF file before printing out the form.

Please fill out and send to your nearest Bürkert facility* with your inquiry or order.



NOTE:

Please take into account that the sensor fitting Type S054 or S055 must be associated with one of the electronic Type SE56.

If only the sensor fitting is ordered, please indicate on your order the version (standard, blind or basic) or better the item no. of the electronics Type SE56 with which it will be associated

Company:	Contact person:
Customer No.:	Department:
Address:	Tel. / Fax.:
Postcode / Town:	E-mail:

Full Bore Magflow sensor body

Wafer version S054:
Flanged version S055:

Quantity:
Desired delivery date:

■ **Pipe diameter:** DN25 DN32 DN40 DN50
 DN65 DN80 DN100 DN > 100 DN value*

■ **Process connection:** EN1092-1 ANSI 150 ANSI 300 JIS 10 K

■ **Pressure:** PN10 PN16 PN25 PN40 PN64

■ **Number of electrodes¹⁾ and lining material:** 2 and PP (PN16) 2 and PTFE (PN40) 3 and PP (PN16) 3 and PTFE (PN40)

■ **Materials:**

Body Carbon steel Stainless steel 304 Stainless steel 316L

Seal FKM EPDM

Electrodes 316L Hastelloy Tantalum
 Titanium Platinum

■ **Flowmeter version:** Compact Remote (10 m cable included)

■ **Cable length:** meter (for cable length > 20 m a preamplifier is included. Caution! Price increase)

* from DN200 up to DN2000: Ebonite or PTFE Lining material (if PTFE not selected then Ebonite in standard)
¹⁾ If the pipe is in plastic then it is advised to choose 3 electrodes, if it is in metal then 2 electrodes are enough.

Electronics SE56 When you click on the orange box "More info.", you will come to our website for the resp. product where you can download the data sheet, and then you can fill out the SE56 request for quotation form.

To find the nearest Bürkert, click on the orange box → www.burkert.com

DTS 1000101296 EN Version: H Status: RL (released | freigegeben | validé) printed: 27.06.2011