



Type 2031 can be combined with...



**Type 8691**

Control head



**Type 8690**

Pneum. control unit with feedback



**Type 1062**

Electrical position feedback

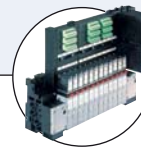

**Type 8640/8644**

Valve block



**Type 6012/6014P**

Pilot valve



**Type 8311**

Pressure Sensor/ Switch

The externally piloted diaphragm valve consists of a pneumatically operated piston actuator, a diaphragm and a 2-way valve housing made of forged stainless steel.

The standard material of the actuator is PPS. With its favourable flow characteristics and zero dead volume, the valve housing enables high flow capacities and a variety of applications to be realized.

**Applications**

- Pharma
- Biotechnology
- Food industry

1) advanced PTFE/EPDM is recommended for sterilization cycle

**2/2-way Diaphragm Valve, forged valve body, weld end and clamp connection, DN 8-100**

- Hermetical separation of fluids from the operating mechanism by diaphragm
- Zero dead volume
- Various surface finishes
- Quality certifications **FDA** / **A** / **USP**

Technical data	
<b>Orifice</b>	DN 8-100
<b>Body material</b>	Forged stainless steel 316 L/1.4435 / BN2 Fe < 0.5% / C ≤ 0.03%
<b>Actuator materials</b>	PPS for actuator size ≥ 40-125mm PA polyamide for actuator size ≥ 175mm
<b>Pilot air ports</b>	Stainless steel 1.4305
<b>Seal material</b>	EPDM, PTFE/EPDM (advanced PTFE/EPDM, FKM on request)
<b>Medium</b>	Neutral gases and liquids, high-purity, sterile, aggressive or abrasive fluids
<b>Viscosity</b>	up to viscous
<b>Surface finish</b>	(Average surface finish) Ra ≤ 0.6 µm  Ra ≤ 0.4 µm
<b>Medium temperatures</b>	EPDM, PTFE/EPDM, advanced PTFE/EPDM (on request) <sup>1)</sup> FKM on request
<b>Ambient temperature</b>	Actuator size < 100mm: +5 to +140°C Actuator size 100-125mm: +5 to +90°C / briefly up to +140°C Actuator size ≥ 175mm: -10 to +50°C
<b>Control medium</b>	Neutral gases; air
<b>Pilot pressure max.</b>	max. 7 bar, see table on p.2
<b>Port connections</b>	
<b>Weld end</b> acc. to	EN ISO 1127/ISO 4200, DIN 11850 R2, SMS 3008, ASME BPE, BS 4825
<b>Clamp</b> acc. to	ISO 2852, DIN 32676, ASME BPE
<b>Sterile threaded ends</b>	on request
<b>Installation</b>	As required, preferably with actuator in upright position

**Content**

Valve specifications	System spec. On/Off Classic	Request for quotation
<b>Type 2031 forged</b>	<b>Type 8801/8803-DB</b>	<b>Type 8801/8803-DB</b>
Technical data & ordering info. p. 1-12	Ordering info. & technical data p 13-16	p. 17

## Technical data, continued

Port connection		Kv-value water [m <sup>3</sup> /h]	Actuator size Ø [mm]	Pilot pressure [bar]		Max. operating pressure for seal material [bar]		Weight [kg]
[mm]	[inch]			min.	max.	EPDM, FKM	PTFE/EPDM, advanced PTFE/EPDM	
8	1/4"	1.0	40	5.0	7	10	10	0.4
10	3/8"	1.0	40	5.0	7	10	10	0.4
15	1/2"	4.0	50	5.0	7	8.5	5	0.7
		4.5	63	5.0	7	10	10	0.9
20	3/4"	7.0	63	5.5	7	10	5	1.3
		7.5	80	5.0	7	10	10	2.0
25	1"	12.0	63	5.0	7	3	–	1.6
			80	5.5	7	10	7.5	2.2
32	1 1/4"	30.0	100	5.5	7	6.5	6	4.2
		30.5	125	5.5	7	10	10	5.7
40	1 1/2"	30.0	100	5.5	7	6.5	6	4.2
		30.5	125	5.5	7	10	10	5.7
50	2"	51.5	100	5.5	7	4.5	2.5	5.9
			125	5.5	7	8	7	7.6
65	2 1/2"	160.0	125	5.5	7	8	7	7.6
			225	5.0	6	10	10	26.0
80	3"	160.0	225	5.0	6	10	10	26.0
100	4"	235.0	225	5.0	6	8	4	38.0

1) Measured at +20°C, 1 bar pressure at valve inlet and free outlet.

**Pressure values (bar):** Gauge pressures with respect to the prevailing atmospheric pressure.

**Remark:**

For low operating pressures we recommend reduced spring versions

## Installation for self-draining operation

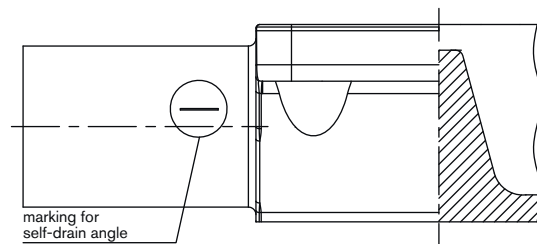
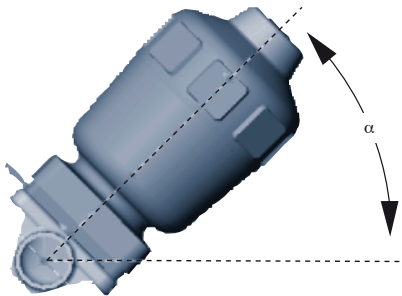

$\alpha = 15$  up to  $35^\circ$  (Marking must face upwards, 12 o'clock position)  
plus  $3^\circ$  to  $5^\circ$  inclination to the pipe axis.  
Drain marks permanently marked on both sides of the valve body  
show the correct mounting position to optimise drain ability.

## Materials

### DN 8-50

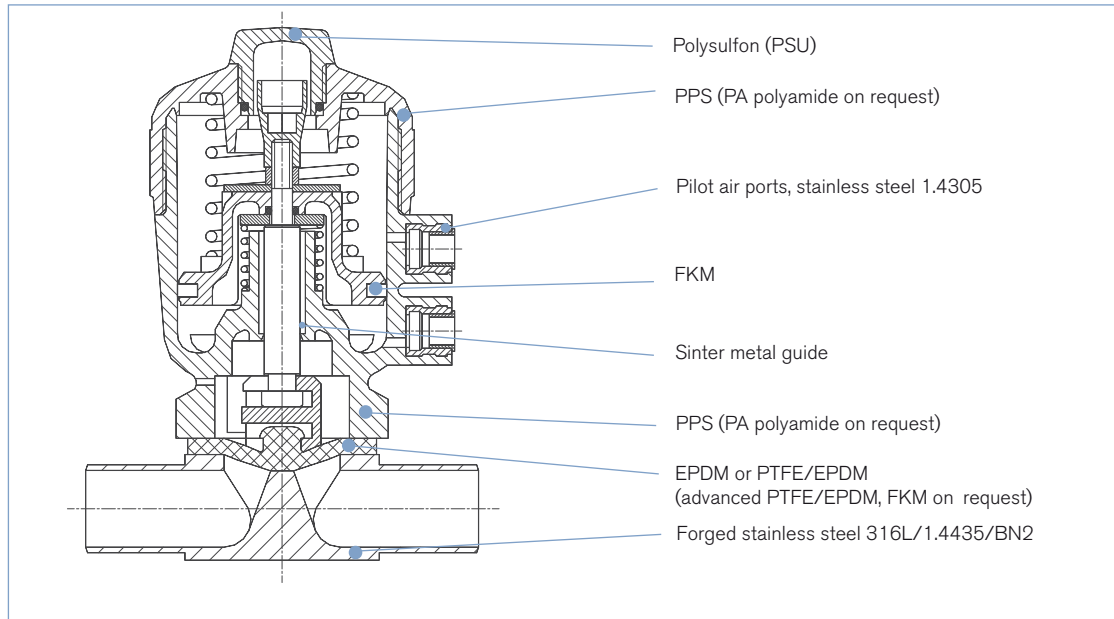

### DN 65-100

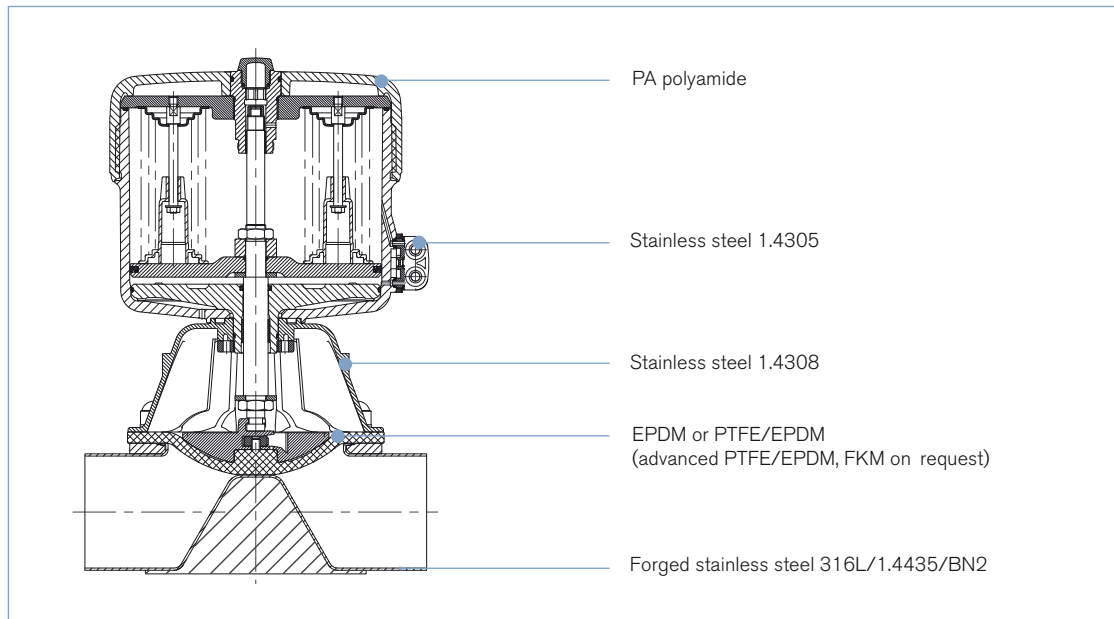

## Approvals

### Suitable for foodstuffs / sterile applications



- The composition of the EPDM, PTFE/EPDM and advanced PTFE/EPDM diaphragms corresponds to the *Code of Federal Regulations*, published by the *FDA* (Food and Drug Administration, USA).



- The diaphragm valves are 3-A approved (3-A Sanitary Standards Symbol Administrative Council)
- The EPDM, PTFE/EPDM and advanced PTFE/EPDM diaphragms are approved acc. USP Class VI

Ordering chart for valves (other versions on request)

Welded connection acc. EN ISO 1127/ISO 4200

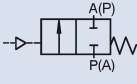
	Port connection		External-Ø [mm]	Kv-value water [m³/h]	Actuator size Ø [mm]	Pilot pressure [bar]	Max. operating pressure [bar]	Item no. mechanical polished, Ra ≤ 0,6 µm	Item no. electro polished, Ra ≤ 0,4 µm
	[mm]	[inch]							
 <p><b>Control function A</b> 2/2-way, NC by spring return</p>	<b>Acc. EN ISO 1127/ISO 4200, diaphragm material EPDM</b>								
	8	1/4"	13.5	1.0	40	5.0-7	10	216 508	444 969
	10	3/8"	17.2	1.0	40	5.0-7	10	216 509	444 974
	15	1/2"	21.3	4.0	50	5.0-7	8.5	216 510	444 979
	20	3/4"	26.9	7.0	63	5.5-7	10	216 511	444 984
	25	1"	33.7	12.0	80	5.5-7	10	216 512	444 989
	32	1 1/4"	42.4	30.0	100	5.5-7	6.5	216 513	550 287
	40	1 1/2"	48.3	30.0	100	5.5-7	6.5	216 514	444 994
	50	2"	60.3	51.5	125	5.5-7	8	216 515	444 999
	65	2 1/2"	76.1	160.0	225	5.0-6	10	216 516	551 400
	80	3"	88.9	160.0	225	5.0-6	10	216 517	551 405
	100	4"	114.3	235.0	225	5.0-6	8	216 518	551 383
	<b>Acc. EN ISO 1127/ISO 4200, diaphragm material PTFE/EPDM</b>								
	8	1/4"	13.5	1.0	40	5.0-7	10	216 519	445 004
	10	3/8"	17.2	1.0	40	5.0-7	10	216 520	445 009
	15	1/2"	21.3	4.5	63	5.0-7	10	216 521	445 014
	20	3/4"	26.9	7.5	80	5.0-7	10	216 522	445 019
	25	1"	33.7	12.0	80	5.5-7	7.5	216 524	445 024
	32	1 1/4"	42.4	30.5	125	5.5-7	10	216 525	555 021
	40	1 1/2"	48.3	30.5	125	5.5-7	10	216 526	445 028
	50	2"	60.3	51.5	125	5.5-7	7	216 527	445 033
	65	2 1/2"	76.1	160.0	225	5.0-6	10	216 528	550 692
80	3"	88.9	160.0	225	5.0-6	10	216 529	550 693	
100	4"	114.3	235.0	225	5.0-6	4	216 530	551 393	

Port connection size equals the orifice diaphragm size except for port connection 32 mm and 65 mm. At port connection 32 mm the orifice diaphragm size equals 40 mm. At port connection 65 mm the orifice diaphragm size equals 80 mm.

**i Further versions on request**

**Material**  
Sealing: advanced PTFE/EPDM, FKM

**> Additional**  
Versions with reduced spring force

## Ordering chart for valves (other versions on request), cont.

## Welded connection acc. DIN 11850 Series 2

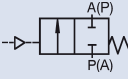
	Port connection		External-Ø [mm]	Kv-value water [m³/h]	Actuator size Ø [mm]	Pilot pressure [bar]	Max. operating pressure [bar]	Item no. mechanical polished, Ra ≤ 0.6 µm	Item no. electro polished, Ra ≤ 0.4 µm	
	[mm]	[inch]								
 <p><b>Control function A</b> 2/2-way, NC by spring return</p>	<b>Acc. DIN 11850 Series 2, diaphragm material EPDM</b>									
	10	3/8"	13.0	1.0	40	5.0-7	10	216 531	445 108	
	15	1/2"	19.0	4.0	50	5.0-7	8.5	216 532	445 113	
	20	3/4"	23.0	7.0	63	5.5-7	10	216 533	445 118	
	25	1"	29.0	12.0	80	5.5-7	10	216 534	445 123	
	32	1 1/4"	35.0	30.0	100	5.5-7	6.5	216 535	449 907	
	40	1 1/2"	41.0	30.0	100	5.5-7	6.5	216 536	445 128	
	50	2"	53.0	51.5	125	5.5-7	8	216 537	445 133	
	65	2 1/2"	70.0	160.0	225	5.0-6	10	216 538	551 415	
	80	3"	85.0	160.0	225	5.0-6	10	216 539	551 420	
	100	4"	104.0	235.0	225	5.0-6	8	216 540	551 389	
	<b>Acc. DIN 11850 Series 2, diaphragm material PTFE/EPDM</b>									
	10	3/8"	13.0	1.0	40	5.0-7	10	216 541	445 138	
	15	1/2"	19.0	4.5	63	5.0-7	10	216 542	445 143	
	20	3/4"	23.0	7.5	80	5.0-7	10	216 543	445 148	
	25	1"	29.0	12.0	80	5.5-7	7.5	216 544	445 153	
	32	1 1/4"	35.0	30.5	125	5.5-7	10	216 545	554 977	
	40	1 1/2"	41.0	30.5	125	5.5-7	10	216 546	445 158	
	50	2"	53.0	51.5	125	5.5-7	7	216 547	445 163	
	65	2 1/2"	70.0	160.0	225	5.0-6	10	216 548	551 445	
80	3"	85.0	160.0	225	5.0-6	10	216 549	551 450		
100	4"	104.0	235.0	225	5.0-6	4	216 550	551 398		

Port connection size equals the orifice diaphragm size except for port connection 32 mm and 65 mm. At port connection 32 mm the orifice diaphragm size equals 40 mm. At port connection 65 mm the orifice diaphragm size equals 80 mm.

### **i** Further versions on request



#### Material

Sealing: advanced PTFE/EPDM, FKM



#### Additional

Versions with reduced spring force

## Ordering chart for valves (other versions on request), cont.

## Welded connection acc. SMS 3008 and BS 4825

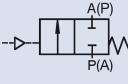
	Port connection		External-Ø [mm]	Kv-value water [m³/h]	Actuator size Ø [mm]	Pilot pressure [bar]	Max. operating pressure [bar]	Item no. mechanical polished, Ra ≤ 0.6 µm	Item no. electro polished, Ra ≤ 0.4 µm
	[mm]	[inch]							
 <p><b>Control function A</b> 2/2-way, NC by spring return</p>	<b>Acc. SMS 3008, diaphragm material EPDM</b>								
	25	1"	25.0	12.0	80	5.5-7	10	216 551	445 168
	40	1 1/2"	38.0	30.0	100	5.5-7	6.5	216 552	445 173
	50	2"	51.0	51.5	125	5.5-7	8	216 553	445 178
	65	2 1/2"	63.5	51.5	125	5.5-7	8	216 554	551 381
	80	3"	76.1	160.0	225	5.0-6	10	216 555	551 410
	100	4"	101.6	235.0	225	5.0-6	8	216 556	551 386
	<b>Acc. SMS 3008, diaphragm material PTFE/EPDM</b>								
	25	1"	25.0	12.0	80	5.5-7	7.5	216 557	445 183
	40	1 1/2"	38.0	30.0	125	5.5-7	10	216 558	445 188
	50	2"	51.0	51.5	125	5.5-7	7	216 559	445 193
	65	2 1/2"	63.5	51.5	125	5.5-7	7	216 560	551 332
	80	3"	76.1	160.0	225	5.0-6	10	216 561	551 440
	100	4"	101.6	235.0	225	5.0-6	4	216 562	551 395
	<b>Acc. BS 4825, diaphragm material EPDM</b>								
	8	1/4"	6.35	1.0	40	5.0-7	10	216 563	445 038
	10	3/8"	9.53	1.0	40	5.0-7	10	216 564	445 043
	15	1/2"	12.70	4.0	50	5.0-7	8.5	216 565	447 887
	20	3/4"	19.05	7.0	63	5.5-7	10	216 566	447 892
	65	2 1/2"	63.5	51.5	125	5.5-7	8	216 554	551 381
	80	3"	76.1	160.0	225	5.0-6	10	216 555	551 410
	100	4"	101.6	235.0	225	5.0-6	8	216 556	551 386
	<b>Acc. BS 4825, diaphragm material PTFE/EPDM</b>								
	8	1/4"	6.35	1.0	40	5.0-7	10	216 567	445 073
	10	3/8"	9.53	1.0	40	5.0-7	10	216 568	445 078
	15	1/2"	12.70	4.0	63	5.5-7	5	216 569	447 906
	20	3/4"	19.05	7.0	80	5.5-7	10	216 570	447 911
	65	2 1/2"	63.5	51.5	125	5.5-7	7	216 560	551 332
80	3"	76.1	160.0	225	5.0-6	10	216 561	551 440	
100	4"	101.6	235.0	225	5.0-6	4	216 562	551 395	

Port connection size equals the orifice diaphragm size except for port connection 65 mm. At port connection 65 mm the orifice diaphragm size equals 50 mm

### **i** Further versions on request



#### Material

Sealing: advanced PTFE/EPDM, FKM



#### Additional

Versions with reduced spring force

Ordering chart for valves (other versions on request), cont.

Welded connection acc. ASME BPE

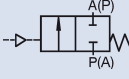
	Port connection		External-Ø [mm]	Kv-value water [m³/h]	Actuator size Ø [mm]	Pilot pressure [bar]	Max. operating pressure [bar]	Item no. mechanical polished, Ra ≤ 0.6 µm	Item no. electro polished, Ra ≤ 0.4 µm	
	[mm]	[inch]								
 <b>Control function A</b> 2/2-way, NC by spring return	<b>Acc. ASME BPE, diaphragm material EPDM</b>									
	8	1/4"	6.35	1.0	40	5.0-7	10	216 571	447 896	
	10	3/8"	9.53	1.0	40	5.0-7	10	216 572	447 901	
	15	1/2"	12.70	4.0	50	5.0-7	8.5	216 573	445 048	
	20	3/4"	19.05	7.0	63	5.5-7	10	216 574	445 053	
	25	1"	25.40	12.0	80	5.5-7	10	216 575	445 058	
	40	1 1/2"	38.10	30.0	100	5.5-7	6.5	216 576	445 063	
	50	2"	50.80	51.5	125	5.5-7	8	216 577	445 068	
	65	2 1/2"	63.5	51.5	125	5.5-7	8	216 554	551 381	
	80	3"	76.1	160.0	225	5.0-6	10	216 555	551 410	
	100	4"	101.6	235.0	225	5.0-6	8	216 556	551 386	
	<b>Acc. ASME BPE, diaphragm material PTFE/EPDM</b>									
	8	1/4"	6.35	1.0	40	5.0-7	10	216 578	447 916	
	10	3/8"	9.53	1.0	40	5.0-7	10	216 579	447 921	
	15	1/2"	12.70	4.0	63	5.0-7	10	216 580	445 083	
	20	3/4"	19.05	7.0	80	5.5-7	10	216 581	445 088	
	25	1"	25.40	12.0	80	5.5-7	7.5	216 583	445 093	
	40	1 1/2"	38.10	30.0	125	5.5-7	10	216 584	445 098	
	50	2"	50.80	51.5	125	5.5-7	7	216 585	445 103	
	65	2 1/2"	63.5	51.5	125	5.5-7	7	216 560	551 332	
80	3"	76.1	160.0	225	5.0-6	10	216 561	551 440		
100	4"	101.6	235.0	225	5.0-6	4	216 562	551 395		

Port connection size equals the orifice diaphragm size except for port connection 65 mm. At port connection 65 mm the orifice diaphragm size equals 50 mm.

**i Further versions on request**

**Material**  
Sealing: advanced PTFE/EPDM, FKM

**> Additional**  
Versions with reduced spring force

Ordering chart for valves (other versions on request), cont.

Clamp connection acc. ISO 2852 - SMS 3017 and DIN 32676

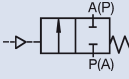
	Port connection		External-Ø [mm]	Kv-value water [m³/h]	Actuator size Ø [mm]	Pilot pressure [bar]	Max. operating pressure [bar]	Item no. mechanical polished, Ra ≤ 0.6 µm	Item no. electro polished, Ra ≤ 0.4 µm
	[mm]	[inch]							
 <b>Control function A</b> 2/2-way, NC by spring return	<b>Acc. ISO 2852 - SMS 3017, diaphragm material EPDM</b>								
	25	1"	22.6	12.0	80	5.5-7	10	216 586	445 388
	40	1 1/2"	35.6	30.0	100	5.5-7	6.5	216 587	445 393
	50	2"	48.6	51.5	125	5.5-7	8	216 588	445 398
	<b>Acc. ISO 2852 - SMS 3017, diaphragm material PTFE/EPDM</b>								
	25	1"	22.6	12.0	80	5.5-7	7.5	216 590	445 403
	40	1 1/2"	35.6	30.5	125	5.5-7	10	216 591	445 408
	50	2"	48.6	51.5	125	5.5-7	7	216 592	445 413
	<b>Acc. DIN 32676, diaphragm material EPDM</b>								
	15	1/2"	16.0	4.0	50	5.0-7	8.5	216 593	445 337
	20	3/4"	20.0	7.0	63	5.5-7	10	216 594	445 342
	25	1"	26.0	12.0	80	5.5-7	10	216 595	445 347
	40	1 1/2"	38.0	30.0	100	5.5-7	6.5	216 596	445 352
	50	2"	50.0	51.5	125	5.5-7	8	216 597	445 357
	<b>Acc. DIN 32676, diaphragm material PTFE/EPDM</b>								
	15	1/2"	16.0	4.5	63	5.0-7	10	216 598	445 362
	20	3/4"	20.0	7.5	80	5.0-7	10	216 599	445 367
	25	1"	26.0	12.0	80	5.5-7	7.5	216 600	445 372
40	1 1/2"	38.0	30.5	125	5.5-7	10	216 601	445 377	
50	2"	50.0	51.5	125	5.5-7	7	216 602	445 382	

**i Further versions on request**

**Material**  
Sealing: advanced PTFE/EPDM, FKM

**> Additional**  
Versions with reduced spring force

Ordering chart for valves (other versions on request), cont.

Clamp connection acc. ASME BPE, short and long connection

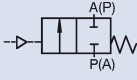
	Port connection		External-Ø [mm]	Kv-value water [m³/h]	Actuator size Ø [mm]	Pilot pressure [bar]	Max. operating pressure [bar]	Item no. mechanical polished, Ra ≤ 0.6 µm	Item no. electro polished, Ra ≤ 0.4 µm	
	[mm]	[inch]								
 <b>Control function A</b> 2/2-way, NC by spring return	<b>Acc. ASME BPE short connection, diaphragm material EPDM</b>									
	8	1/4"	25.0	1.0	40	5.0-7	10	216 603	445 267	
	10	3/8"	25.0	1.0	40	5.0-7	10	216 604	445 272	
	15	1/2"	25.0	4.0	50	5.0-7	8.5	216 605	445 277	
	20	3/4"	25.0	7.0	63	5.5-7	10	216 606	445 282	
	25	1"	50.5	12.0	80	5.5-7	10	216 607	445 287	
	40	1 1/2"	50.5	30.0	100	5.5-7	6.5	216 608	445 292	
	50	2"	64.0	51.5	125	5.5-7	8	216 609	445 297	
	65	2 1/2"	77.5	51.5	125	5.5-7	8	216 610	551 466	
	80	3"	91.0	160.0	225	5.0-6	10	216 611	551 425	
	<b>Acc. ASME BPE short connection, diaphragm material PTFE/EPDM</b>									
	8	1/4"	25.0	1.0	40	5.0-7	10	216 613	445 302	
	10	3/8"	25.0	1.0	40	5.0-7	10	216 614	445 307	
	15	1/2"	25.0	4.0	63	5.0-7	10	216 615	445 312	
	20	3/4"	25.0	7.0	80	5.5-7	10	216 616	445 317	
	25	1"	50.5	12.0	80	5.5-7	7.5	216 617	445 322	
	40	1 1/2"	50.5	30.0	125	5.5-7	10	216 618	445 327	
	50	2"	64.0	51.5	125	5.5-7	7	216 621	445 332	
	65	2 1/2"	77.5	51.5	125	5.5-7	7	216 622	551 474	
	80	3"	91.0	160.0	225	5.0-6	10	216 623	551 157	
	<b>Acc. ASME BPE long connection, diaphragm material EPDM</b>									
	8	1/4"	25.0	1.0	40	5.0-7	10	216 624	445 198	
	15	1/2"	25.0	4.0	50	5.0-7	8.5	216 625	445 208	
	20	3/4"	25.0	7.0	63	5.5-7	10	216 626	445 213	
	25	1"	50.5	12.0	80	5.5-7	10	216 627	445 217	
	40	1 1/2"	50.5	30.0	100	5.5-7	6.5	216 628	445 222	
	50	2"	64.0	51.5	125	5.5-7	8	216 629	445 227	
	<b>Acc. ASME BPE long connection, diaphragm material PTFE/EPDM</b>									
	8	1/4"	25.0	1.0	40	5.0-7	10	216 630	445 232	
	15	1/2"	25.0	4.0	63	5.0-7	10	216 631	445 242	
	20	3/4"	25.0	7.0	80	5.5-7	10	216 632	445 247	
	25	1"	50.5	12.0	80	5.5-7	7.5	216 633	445 252	
	40	1 1/2"	50.5	30.0	125	5.5-7	10	216 634	445 257	
	50	2"	64.0	51.5	125	5.5-7	7	216 635	445 262	

Port connection size equals the orifice diaphragm size except for port connection 65 mm. At port connection 65 mm the orifice diaphragm size equals 50 mm.

**i Further versions on request**

**Material**  
Sealing: advanced PTFE/EPDM, FKM

**> Additional**  
Versions with reduced spring force

DTS 1000010981 EN Version: V Status: RL (released | freigegeben | validé) printed: 18.08.2011

Dimensions [mm]

Welded connection

DN 8-50

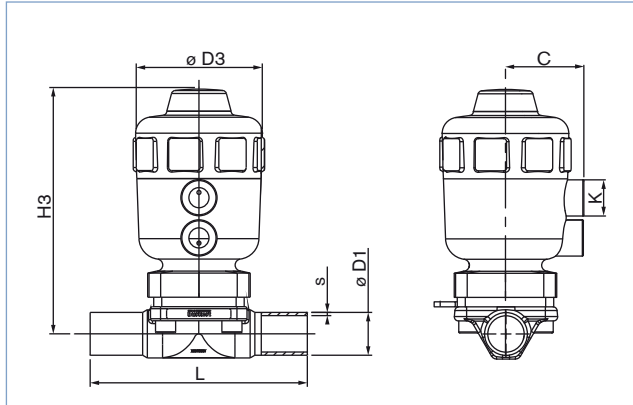

DN 65-80

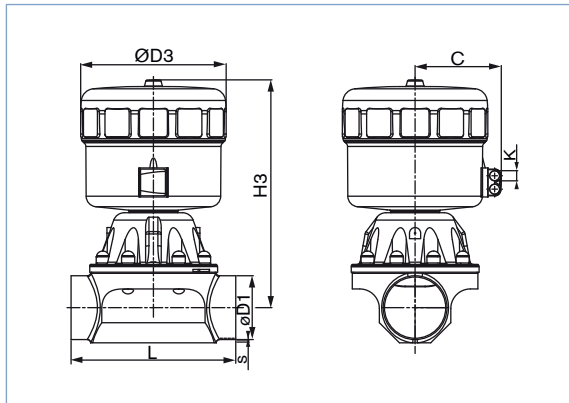

DN 100

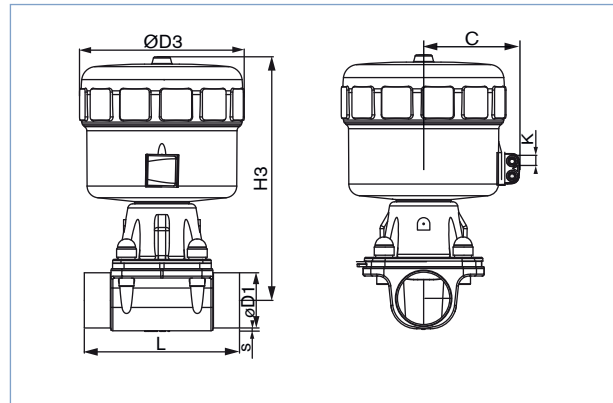

Dimensions acc. to EN ISO 1127/ISO 4200, DIN 11850 S2 and SMS 3008 [mm]

Port connection		Actuator size Ø	C	K	L	H3	ØD3	EN ISO 1127/ ISO 4200		DIN 11850 S2		SMS 3008	
[mm]	[inch]							ØD1	s	ØD1	s	ØD1	s
8	1/4"	40	34	G 1/8	90.0	85.0	53.0	13.5	1.6	-	-	-	-
10	3/8"	40	34	G 1/8	90.0	85.0	53.0	17.2	1.6	13.0	1.5	-	-
15	1/2"	50	39	G 1/8	110.0	121.0	64.0	21.3	1.6	19.0	1.5	-	-
		63	52	G 1/4	110.0	138.0	80.0	21.3	1.6	23.0	1.5	-	-
20	3/4"	63	52	G 1/4	119.0	148.0	80.0	26.9	1.6	23.0	1.5	-	-
		80	60	G 1/4	119.0	174.0	101.0	26.9	1.6	23.0	1.5	-	-
25	1"	63	52	G 1/4	129.0	157.0	80.0	33.7	2.0	29.0	1.5	25.0	1.2
		80	60	G 1/4	129.0	177.0	101.0	33.7	2.0	29.0	1.5	25.0	1.2
32	1 1/4"	100	73	G 1/4	161.0	233.0	127.0	42.4	2.0	35.0	1.5	38.0	1.2
		125	86	G 1/4	161.0	272.0	153.0	42.4	2.0	35.0	1.5	38.0	1.2
40	1 1/2"	100	73	G 1/4	161.0	233.0	127.0	48.3	2.0	41.0	1.5	38.0	1.2
		125	86	G 1/4	161.0	272.0	153.0	48.3	2.0	41.0	1.5	38.0	1.2
50	2"	100	73	G 1/4	192.0	244.0	127.0	60.3	2.0	53.0	1.5	51.0	1.2
		125	86	G 1/4	192.0	278.0	153.0	60.3	2.0	53.0	1.5	51.0	1.2
65	2 1/2"	125	86	G 1/4	190.0	278.0	153.0	76.1	2.0	70.0	2.0	63.5	1.6
		225	155	G 1/4	250.0	394.0	261.0	76.1	2.0	70.0	2.0	-	-
80	3"	225	155	G 1/4	250.0	394.0	261.0	88.9	2.3	85.0	2.0	76.15	1.6
100	4"	225	155	G 1/4	295.0	409.0	261.0	114.3	2.3	104.0	2.0	101.6	2.0

## Dimensions [mm]

Welded connection, *cont.*

Dimensions acc. to BS 4825 and ASME BPE [mm]

Port connection		Actuator size Ø	C	K	L	H3	ØD3	BS 4825		ASME BPE	
[mm]	[inch]							ØD1	s	ØD1	s
8	1/4"	40	34	G 1/8	78.0	85.0	53.0	6.35	1.2	6.35	0.89
10	3/8"	40	34	G 1/8	89.0	85.0	53.0	9.53	1.2	9.53	0.89
15	1/2"	50	39	G 1/8	108.0	121.0	64.0	12.70	1.2	12.70	1.65
		63	52	G 1/4	108.0	138.0	80.0	12.70	1.2	12.70	1.65
20	3/4"	63	52	G 1/4	117.0	148.0	80.0	19.05	1.2	19.05	1.65
		80	60	G 1/4	117.0	174.0	101.0	19.05	1.2	19.05	1.65
25	1"	63	52	G 1/4	127.0	157.0	80.0	25.40	1.65	25.40	1.65
		80	60	G 1/4	127.0	177.0	101.0	25.40	1.65	25.40	1.65
40	1 1/2"	100	73	G 1/4	159.0	233.0	127.0	38.10	1.65	38.10	1.65
		125	86	G 1/4	159.0	272.0	153.0	38.10	1.65	38.10	1.65
50	2"	100	73	G 1/4	190.0	244.0	127.0	50.80	1.65	50.80	1.65
		125	86	G 1/4	190.0	278.0	153.0	50.80	1.65	50.80	1.65
65	2 1/2"	125	86	G 1/4	190.0	278.0	153.0	–	–	63.5	1.65
80	3"	225	155	G 1/4	250.0	394.0	261.0	–	–	76.15	1.65
100	4"	225	155	G 1/4	295.0	409.0	261.0	–	–	101.6	2.0

Dimensions [mm]

Clamp connection

DN 8-50

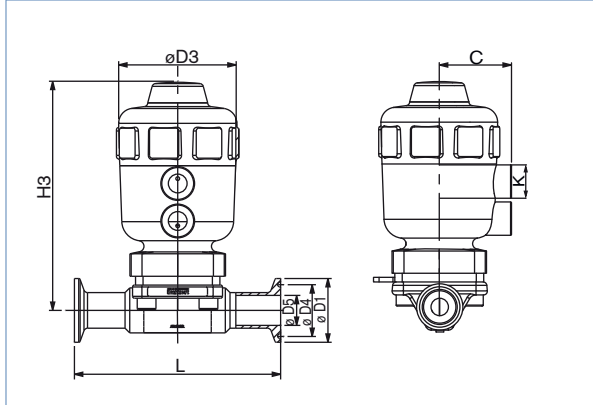

DN 65-80

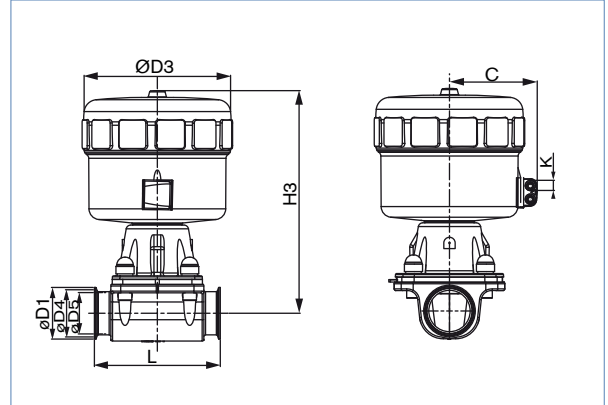

Dimensions acc. to ISO 2852 and DIN 32676 [mm]

Port connection [mm]	[inch]	Actuator size		L	H3	ØD3	ØD1	ØD4	ISO 2852 ØD5	DIN 32676 ØD5	
		Ø	C								
15	1/2"	50	39	G 1/8	110.0	121.0	64.0	34.0	27.5	-	16.0
		63	52	G 1/4	110.0	138.0	80.0	34.0	27.5	-	16.0
20	3/4"	63	52	G 1/4	119.0	148.0	80.0	34.0	27.5	-	20.0
		80	60	G 1/4	119.0	174.0	101.0	34.0	27.5	-	20.0
25	1"	63	52	G 1/4	129.0	157.0	80.0	50.5	43.5	22.6	26.0
		80	60	G 1/4	129.0	177.0	101.0	50.5	43.5	22.6	26.0
40	1 1/2"	100	73	G 1/4	161.0	233.0	127.0	50.5	43.5	35.6	38.0
		125	86	G 1/4	161.0	272.0	153.0	50.5	43.5	35.6	38.0
50	2"	100	73	G 1/4	192.0	244.0	127.0	64.0	56.5	48.6	50.0
		125	86	G 1/4	192.0	278.0	153.0	64.0	56.5	48.6	50.0

Dimensions acc. to ASME BPE long connection and short connection [mm]

Port connection [mm]	[inch]	Actuator size		Long conn. L	Short conn. L	H3	ØD3	ØD1	ØD4	ØD5	
		Ø	C								
8	1/4"	40	34	G 1/8	78.0	64.5	85.0	53.0	25.0	20.22	4.57
10	3/8"	40	34	G 1/8	89.0	89.0	85.0	53.0	25.0	20.22	7.75
15	1/2"	50	39	G 1/8	108.0	89.0	121.0	64.0	25.0	20.22	9.40
		63	52	G 1/4	108.0	89.0	138.0	80.0	25.0	20.22	9.40
20	3/4"	63	52	G 1/4	117.0	102.0	148.0	80.0	25.0	20.22	15.75
		80	60	G 1/4	117.0	102.0	174.0	101.0	25.0	20.22	15.75
25	1"	63	52	G 1/4	127.0	114.0	157.0	80.0	50.5	43.5	22.20
		80	60	G 1/4	127.0	114.0	177.0	101.0	50.5	43.5	22.20
40	1 1/2"	100	73	G 1/4	159.0	140.0	233.0	127.0	50.5	43.5	34.90
		125	86	G 1/4	159.0	140.0	272.0	153.0	50.5	43.5	34.90
50	2"	100	73	G 1/4	190.0	159.0	244.0	127.0	64.0	56.5	47.60
		125	86	G 1/4	190.0	159.0	278.0	153.0	64.0	56.5	47.60
65	2 1/2"	125	86	G 1/4	-	190.0	278.0	153.0	77.5	70.5	60.2
80	3"	225	155	G 1/4	-	222.0	394.0	261.0	91.0	83.5	72.9

**Ordering information for valve system On/Off Classic Type 8801-DB/8803-DB**

A valve system On/Off Classic Type 8801-DB/8803-DB consists of a diaphragm valve Type 2031 and a valve actuation system control head Type 8691, a pneumatic control unit Type 8690 or an electrical position feedback Type 1062 (see separate datasheets).

For the configuration of further valve systems please use the "Request for quotation" on p. 17 [go to page](#)

You order two components and receive a complete assembled and certified valve.

**Ordering the valve system On/Off Classic Type 8801-DB/8803-DB**

**Diaphragm valve Type 2031  
with required port connection**



**Control units**



Control head  
Type 8691



Pneum.  
control unit  
Type 8690



Electrical  
position  
feedback  
Type 1062

**Diaphragm valve with  
desired control unit**



Valve system  
On/Off Classic  
Type 8801-DB-H  
2031 + 8691



Valve system  
On/Off Classic  
Type 8801-DB-K  
2031 + 8690



Valve system  
On/Off Classic  
Type 8803-DB  
2031 + 1062

When you click on the orange box "More info." below, you will come to our website for the resp. product where you can download the datasheet.

**Control head Type 8691**



**More info.**

The new generation of integrated control heads for combination with actuators from the process valve series Type 20xx/21xx is specially designed for the requirements of hygienic process environments. The intelligent control head, Type 8691, detects the valve position by means of a contact-free analog position sensor circumventing excessive wear of mechanical parts. Single or double-acting actuators are controlled via the integral pilot valve. Communication interfaces AS-Interface and DeviceNet are available as options.

**Main customer benefits:**

- Automatic setting of the control head at the push of a button
- Even under dirty or dark environments, a clearly visible status display due to powerful LEDs
- Monitoring and diagnosis: Process valve systems with field bus interface used in modern plant processes
- Integrated pilot valve with manual actuation
- Air intake filter enhances the process valve system availability
- Simple and reliable actuator adaptations allowing additional actuators of the process valve series, Type 20xx or actuators from other manufacturers to be used

**Pneumatic control unit  
Type 8690**



**More info.**

The new generation of integrated controllers for combination with actuators from the process valve series Type 20xx/21xx is specially designed for the requirements of hygienic process environments. The pneumatic control unit Type 8690 combines electrical position feedback and pneumatic control for single or double-acting actuators, and is also optionally available as an intrinsically safe model to ATEX.

**Main customer benefits:**

- Integrated pilot valve with manual actuation
- Air intake filter enhances the process valve system availability
- Simple and reliable actuator adaptations allowing additional actuators of the process valve series, Type 20xx or actuators from other manufacturers to be used

**Electrical Position Feedback  
Type 1062**



**More info.**

Positions are electrically signaled according to switch type:

- open,
- closed or
- open and closed.

LEDs provide optical position indication (except for Namur Ex-version). Mechanical or inductive switches are housed in a compact splash-proof enclosure. The position indicator can be rotated 360° and is easily fitted to the valve. Trip cams do not require adjustment. The unit only needs to be screwed on and connected to be ready for operation.

Dimensions for valve system On/Off Classic Type 8801-DB-H [mm]

Dimensions valve system On/Off Classic Type 8801-DB-H with control head Type 8691 [mm]

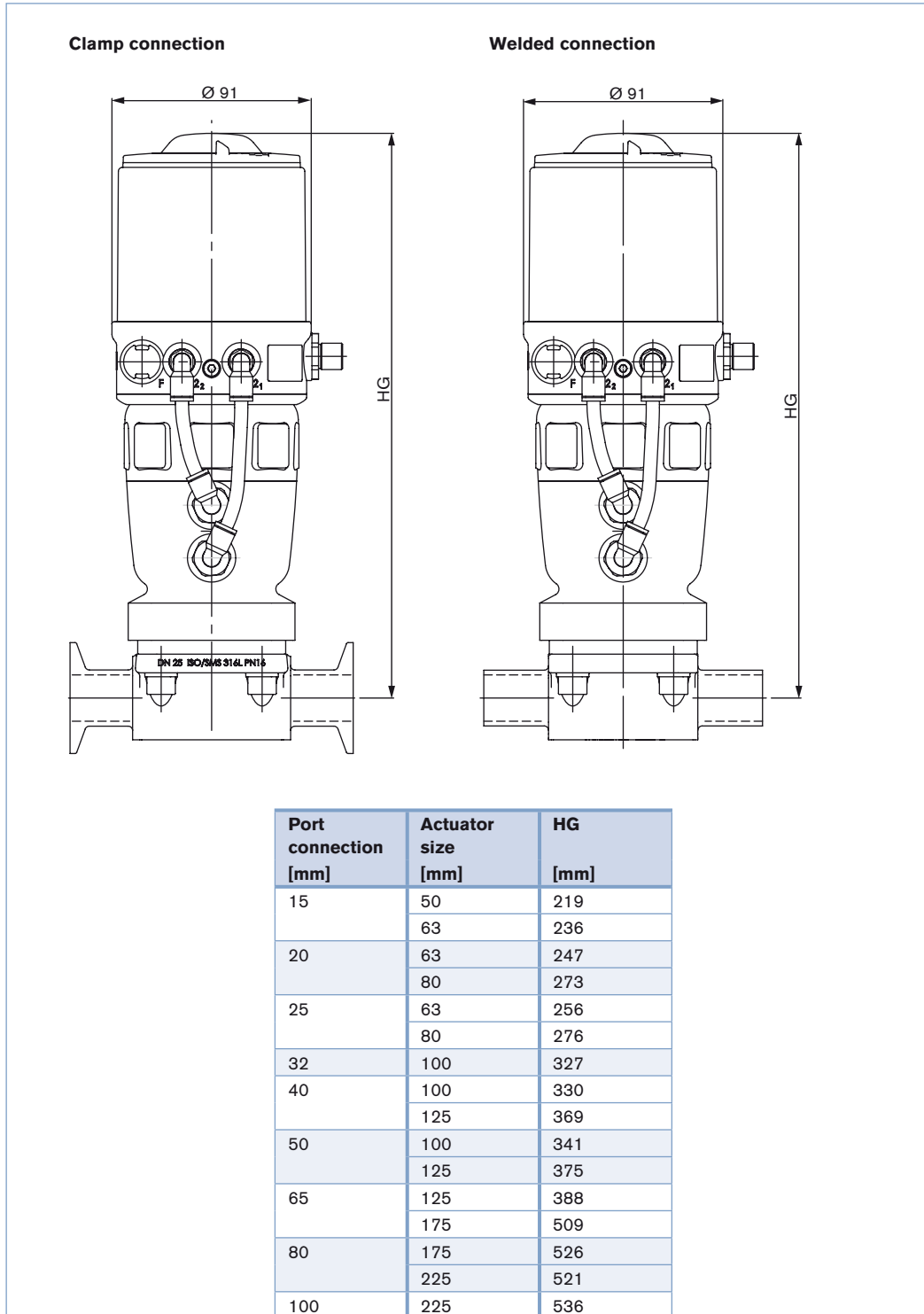

Dimensions for valve system On/Off Classic Type 8801-DB-K [mm]

Dimensions valve system On/Off Classic Type 8801-DB-K with pneumatic control unit Type 8690 [mm]

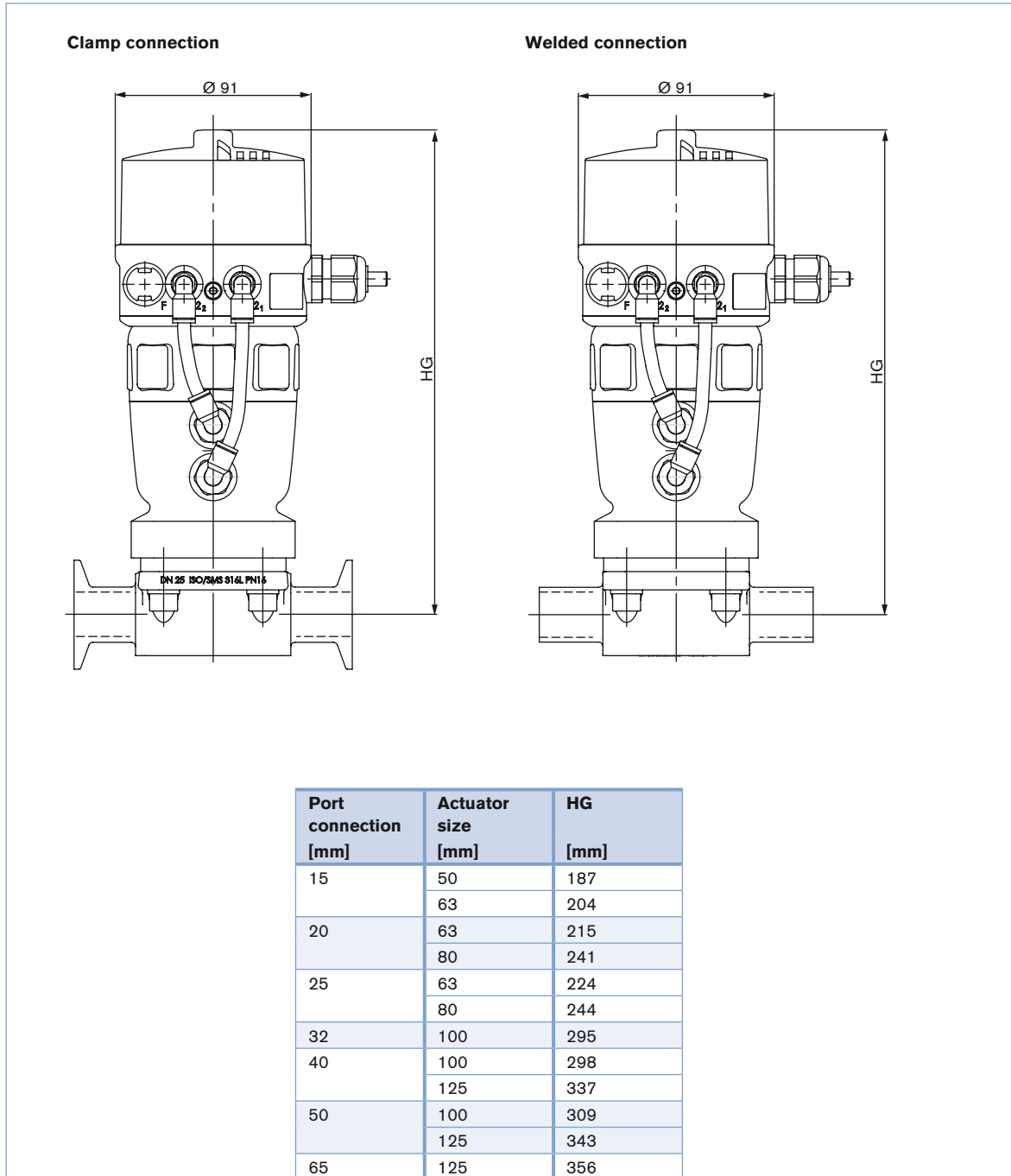

Dimensions for valve system On/Off Classic Type 8803-DB [mm]

Dimensions valve system On/Off Classic Type 8803-DB with electrical position feedback Type 1062 [mm]

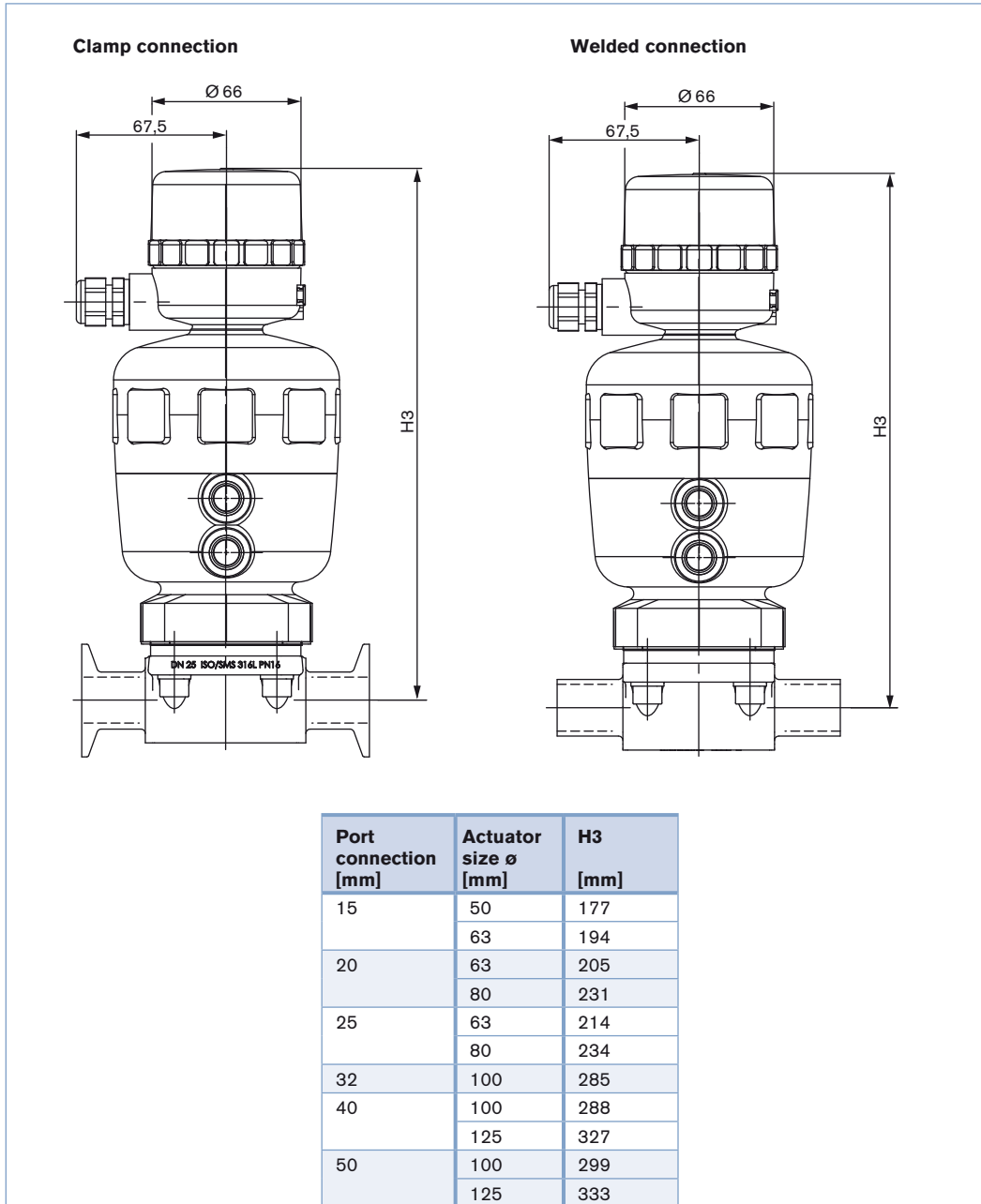

Valve system On/Off Classic Type 8801-DB/8803-DB – request for quotation

Please fill out and send to your nearest Bürkert facility\* with your inquiry or order

Company	Contact person
Customer no.	Department
Address	Tel./Fax
Postcode/town	E-Mail

= mandatory fields to fill out

Quantity

Required delivery date

Operating data

Pipeline	DN <input type="text"/>	PN <input type="text"/>
Pipe material	<input type="text"/>	
Process medium	<input type="text"/>	
Type of medium	<input type="checkbox"/> Liquid	<input type="checkbox"/> Steam
	standard	unit
Flow rate (Q, Q <sub>N</sub> , W) <sup>1)</sup>	<input type="text"/>	<input type="text"/>
Temperature at valve inlet	<input type="text"/>	<input type="text"/>
Absolute pressure at valve inlet	<input type="text"/>	<input type="text"/>
Steam sterilisation	temperature	<input type="text"/>

<sup>1)</sup> standard unit: Liquid Q = m<sup>3</sup>/h; Steam W = kg/h; Gas Q<sub>N</sub> = Nm<sup>3</sup>/h

Valve features

Specification key

automatically transferred from last page

go to page

Surface finish (if not standard)

internal  μm

external  μm

Pilot pressure

min.

max.

Control unit features

Click on the orange box "More info." below... you will come to our website for the resp. product where you can download the datasheet.

Control head

Type 8691

More info.

Pneumatic function

Single-acting  Double-acting

Pilot air ports

Push-in connector external ø 6 mm or 1/4"

Thread G 1/8"

Communication

ASI

Multipol M12

Flat cable clip, 1 m cable

DeviceNet

Please specify item no. if known:

Pneumatic control unit

Type 8690

More info.

Pneumatic function

Single-acting  Double-acting

Without pilot valve

Position feedback

1x inductive  2x inductive

1x inductive (NAMUR)  2x inductive (NAMUR)

1x mechanical  2x mechanical

Supply voltage

24 V / DC (ATEX Zone 2/22)

Ex ia IIC T6 (ATEX Zone 1)

Pilot air ports

Push-in connector  Thread G 1/8"

external ø 6 mm or 1/4"

Please specify item no. if known:

Electrical position feedback

Type 1062

More info.

Limit switches

mechanical

Voltage 12-48 V

Voltage 110-250 V

inductive

NAMUR EExi

Status

closed

open

open/closed

Please specify item no. if known:

continued on next page →

\* To find your nearest Bürkert facility, click on the orange box →

[www.burkert.com](http://www.burkert.com)

Valve system On/Off Classic Type 8801-DB/8803-DB – request for quotation, *cont.*

Control unit features	
<b>Pilot valve</b>	<b>Stroke limitation</b>
<input type="checkbox"/> Pilot valve	<input type="checkbox"/> Stroke limitation
Power supply <input type="text"/>	<input type="checkbox"/> <b>Min./max. stroke limitation</b> , with visual position indicator
	<input type="checkbox"/> <b>Max. stroke limitation</b> , without visual position indicator
Please specify item no. if known: <input type="text"/>	Please specify item no. if known: <input type="text"/>

Certifications
<input type="checkbox"/> Attestation of compliance with the order EN-ISO 10204 2.1 (Item-No. 440 788)
<input type="checkbox"/> Test report EN-ISO 10204 2.2 (Item-No. 803 722)
<input type="checkbox"/> Certification of Conformity for Raw Material EN-ISO 10204 3.1 (included in delivery)
<input type="checkbox"/> EN161 (European Gas Device guideline)
<input type="checkbox"/> FDA - USP certificate

Comment / sketch

DTS 1000010981 EN Version: V Status: RL (released | freigegeben | validé) printed: 18.08.2011

Valve features, specification key

Example

A 15 AB VS SA42 NO17

Specification key

Please make a choice

CONTROL FUNCTION

A	normally closed by spring action
B	normally open by spring action
I	double acting

SIZE [mm]

08
10
15
20
25
32
40
50
65
80
100

SEAL MATERIAL

AB	EPDM in food quality
EA	PTFE/EPDM
FF	FKM
EU	advanced PTFE/EPDM in two pieces
ET	advanced PTFE (bonded on EPDM)

BODY MATERIAL

Standard DN 8-80	VS	Forged 1.4435BN2/ASME BPE
Standard DN 100	VH	Cast stainless steel 1.4435/AISI 316L

VARIABLE CODES

Surface finish, internal	
NO14	Mechanical polished Ra=0.5µm
NO17	Electro polished Ra=0.4µm
NO23	Mechanical polished Ra=0.6µm

Standard



PORT CONNECTION

Welded

Port conn. [mm]	EN ISO 1127/ISO 4200	DIN 11850				ASME BPE	JIS Sanitary	JIS Utility
		SMS 3008	Serie 1	Serie 2	BS 4825			
8	SA40=13.5x1.6				SODB=6.35x1.2	SA90=6.35x0.89	SA70=13.8x1.65	
10	SA41=17.2x1.6		SF40=12x1.0	SD40=13x1.5	SODC=9.53x1.2	SA91=9.53x0.89	SA71=17.3x1.65	
15	SA42=21.3x1.6		SF41=18x1.0	SD42=19x1.5	SODD=12.7x1.2	SA92=12.7x1.65	SA72=21.7x2.1	
20	SA43=26.9x1.6		SF42=22x1.0	SD43=23x1.5	SODE=19.05x1.2	SA93=19.05x1.65	SA76=27.2x2.1	SA80=27.2x2.1
25	SA44=33.7x2.0	SA60=25.0x1.2	SF43=28x1.0	SD44=29x1.5	SODF=25.4x1.65	SODF=25.4x1.65	SA73=25.4x1.2	SA81=34x2.0
32	SA45=42.4x2.0		SF44=34x1.0	SD45=35x1.5				SA83=42.7x2.0
40	SA46=48.3x2.0	SA62=38.0x1.2	SF45=40x1.0	SD46=41x1.5	SODH=38.1x1.65	SODH=38.1x1.65	SA74=38.1x1.2	SA84=60.5x2.0
50	SA47=60.3x2.0	SA63=51.0x1.2	SF46=52x1.0	SD47=53x1.5	SODI=50.8x1.65	SODI=50.8x1.65	SA75=50.8x1.5	
65	SA48=76.1x2.0	SA64=63.5x1.6		SD48=70x2.0	SA64=63.5x1.65	SA64=63.5x1.65		
80	SA49=88.9x2.3	SA65=76.1x1.6		SD49=85x2.0	SA65=76.2x1.65	SA65=76.2x1.65		
100	SA39=114.3x2.3	SA66=101.6x2.0		SD50=104x2.0	SA66=101.6x2.11	SA66=101.6x2.11		

Clamp

Port conn. [mm]	ISO 2852 SMS 3017	ASME BPE		DIN 32676
		Short version	Long version	
8	TC51=Clamp 34 - for tube ISO 4200	TI40=Clamp 25 - Tube 6.35x0.89	TG40=Clamp 25 - Tube 6.35x0.89	
10	TC41=Clamp 34 - for tube ISO 4200	TI41=Clamp 25 - Tube 9.53x0.89	TG41=Clamp 25 - Tube 9.53x0.89	TD41=Clamp 34 - Tube 13x1.5
15	TC42=Clamp 34 - for tube ISO 4200	TI42=Clamp 25 - Tube 12.7x1.65	TG42=Clamp 25 - Tube 12.7x1.65	TD42=Clamp 34 - Tube 19x1.5
20	TC43=Clamp 50.5 - for tube ISO 4200	TI43=Clamp 25 - Tube 19.05x1.65	TG43=Clamp 25 - Tube 19.05x1.65	TD43=Clamp 34 - Tube 23x1.5
25	TC44=Clamp 50.5 - for tube ISO 4200	TI44=Clamp 50.5 - Tube 25.4x1.65	TG44=Clamp 50.5 - Tube 25.4x1.65	TD44=Clamp 50.5 - Tube 29x1.5
40	TC46=Clamp 64 - for tube ISO 4200	TI46=Clamp 50.5 - Tube 38.1x1.65	TG45=Clamp 50.5 - Tube 38.1x1.65	TD46=Clamp 50.5 - Tube 41x1.5
50	TC47=Clamp 77.5 - for tube ISO 4200	TI47=Clamp 64 - Tube 50.8x1.65	TG46=Clamp 64 - Tube 50.8x1.65	TD47=Clamp 64 - Tube 53x1.5
65			TG47=Clamp 77.5 - Tube 63.5x1.65	
80			TG48=Clamp 91 - Tube 76.1x1.65	
100			TG49=Clamp 119 - Tube 101.6x2.11	

In case of special application conditions, please consult for advice.

Subject to alteration.  
© Christian Bürkert GmbH & Co. KG

1107/15\_EU-en\_00891678